

Big Blue® 400 and 500

Issued March 2006 • Index No. ED/10.8

Engine-Driven
Welder/Generator 

Quick Specs

Heavy Industrial Applications

Heavy Construction
Structural Steel
Maintenance and Repair Rigs
Mining Maintenance
Process Piping
Sheet Metal

Processes

Stick (SMAW)
MIG (GMAW)
Flux Cored (FCAW)
DC TIG (GTAW)
Submerged Arc (SAW)
Stud Welding
Air Carbon Arc (CAC-A)
400: (Rated) 5/16 in (8 mm) Carbons
(Capable) 3/8 in (9.5 mm) Carbons
500: (Rated) 3/8 in (9.5 mm) Carbons

Output Range

400: DC Stick 55–500 A MIG/FCAW 14–40 V
500: DC Stick 65–600 A MIG/FCAW 14–40 V

Weld Output Rated at 104°F (40°C)

400: 400 A at 36 V (14.4 kW), 100% Duty Cycle
500: 500 A at 40 V (20 kW), 100% Duty Cycle

Generator Output Rated at 104°F (40°C)

5500 Watts Peak—4000 Watts Continuous
400: 15,000 Watts 3-Phase/12,000 Watts 1-Phase*
500: 20,000 Watts 3-Phase/12,000 Watts 1-Phase*

*Deluxe models only.

The Power of Blue.®

Prior Big Blue 302 owners now have a choice between the Big Blue 400 or the PRO 300.

Engine gauges standard on all models indicate engine oil pressure, coolant temperature.

Designed for fleet owners that demand the ultimate in reliability and performance.

Enclosed robust case design protects internal components from impact and allows air flow to cool and prolong the life of the engine. Also reduces sound levels.

Quick and easy maintenance with single-side access to oil level check, oil fill, oil filter, fuel filter and air cleaner.

Remote toolless oil drain allows oil to be drained without getting under the engine and reduces the chance of oil spillage.



Heavy duty industrial engine choices designed, built and proven to operate over 10,000 hours before the first basic overhaul.



Big Blue 400 CC/CV Deluxe Model

Arc-Drive makes welding easy. Automatically enhances Stick welding, especially on pipe, by focusing the arc and preventing the electrode from going out.

Hot Start™ provides positive Stick electrode starts making it easy to start all types of electrodes and it also works great for bead tie-ins.

Weatherproof Lexan® nameplate resists cracking and fading, and is color-coded for ease of operation.

GFCI receptacle as required on most job sites to protect operators from electrical hazards.

CSA, IEC and NEMA compliant for welders. Degree of protection provided by enclosure IP23.



Welder/generator is warranted by Miller for 3 years, parts and labor.
Engine is warranted separately by engine manufacturer.

MADE IN USA
APPLETON, WI



Miller Electric Mfg. Co.
An Illinois Tool Works Company
1635 West Spencer Street
Appleton, WI 54914 USA

International Headquarters
Phone: 920-735-4505
USA FAX: 920-735-4134
Canadian FAX: 920-735-4169
International FAX: 920-735-4125

Web Site
www.MillerWelds.com



Big Blue 400 and 500 CC Specifications (Subject to change without notice.)



Model	Welding Mode	Weld Output Range	Weld Output Rated at 104°F (40°C)	Max. Open-Circuit Voltage	Generator Output Rated at 104°F (40°C)	Dimensions**	Weight (without fuel)***
Big Blue 400 CC	CC/DC	55–500 A	400 A at 36 V (14.4 kW),* 100% Duty Cycle 450 A at 38 V (17.1 kW),* 60% Duty Cycle 500 A at 30 V (15 kW), 40% Duty Cycle	95	Peak: 5500 watts Continuous: 4000 watts, 34/17 A, 120/240 VAC, 50/60 Hz while welding	H: 43 in (1092 mm) W: 28-1/2 in (724 mm) D: 64-7/16 in (1637 mm)	Perkins: 1545 lb (701 kg) Deutz: 1655 lb (751 kg)
Big Blue 500 CC		65–600 A	500 A at 40 V (20 kW),* 100% Duty Cycle 550 A at 34 V (18.7 kW), 60% Duty Cycle 600 A at 30 V (18 kW), 40% Duty Cycle				Perkins: 1565 lb (710 kg) Deutz: 1695 lb (769 kg)

*NEMA EW1 (ANSI C87.1) Class (1) output ratings. **Additional 7 in (178 mm) to top of exhaust. ***Additional 190 lb (86 kg) when fuel tank is full.

CSA certification by Canadian Standards Association.

Big Blue 400 and 500 CC Control Panel

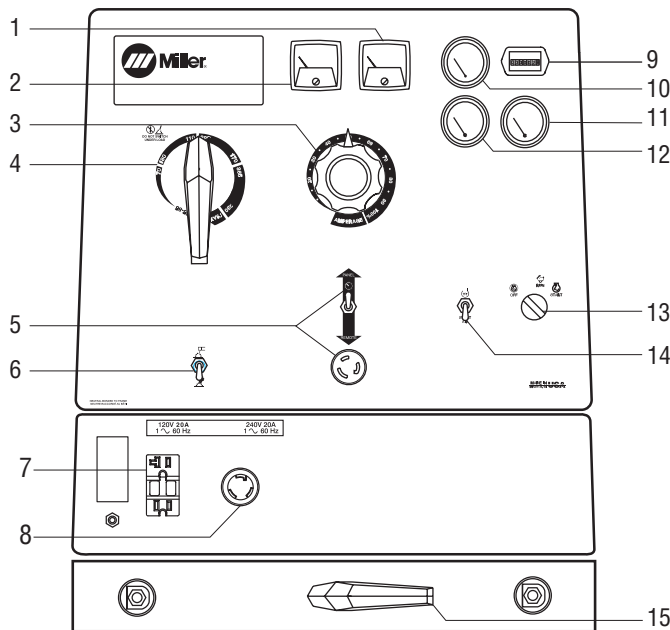

1. DC Ammeter*
2. DC Voltmeter*
3. Amperage Adjust Control
4. Amperage Range Switch
5. Amperage Adjust Switch and Remote Amperage Adjust Receptacle
6. Stick/TIG Selector Switch
7. 120 VAC, 20 A GFCI Duplex Receptacle
8. 240 VAC, 30 A TwistLock Receptacle (NEMA L6-30)
9. Engine Hour Meter
10. Engine Oil Pressure Gauge
11. Fuel Gauge
12. Engine Coolant Temperature Gauge
13. Engine Control Switch
14. Starting Aid Switch
15. Polarity Switch*

*Optional.

Additional Features

Proven, rugged rheostat control technology that has been in Miller engine drives for over 60 years. Contains no printed control boards.

A **Stick/TIG switch** optimizes open-circuit voltage for Stick welding and allows the open-circuit voltage to be lowered for scratch start TIG welding.

Provisions are provided to plug a **RHC3GD34A remote control** that will allow precise adjustment of amperage without walking back to the machine.

Big Blue 400 and 500 CC/CV Specifications (Subject to change without notice.)



Model	Welding Mode	Weld Output Range	Weld Output Rated at 104°F (40°C)	Max. Open-Circuit Voltage	Generator Output Rated at 104°F (40°C)	Dimensions**	Weight (without fuel)***
Big Blue 400 CC/CV	CC/DC CV/DC	20–550 A 14–40 V	400 A at 36 V (14.4 kW),* 100% Duty Cycle 450 A at 38 V (17.1 kW),* 60% Duty Cycle 500 A at 34 V (17 kW), 40% Duty Cycle	95	Peak: 5500 watts Continuous: 4000 watts, 34/17 A, 120/240 VAC, 50/60 Hz while welding	H: 43 in (1092 mm) W: 28-1/2 in (724 mm) D: 64-7/16 in (1637 mm)	Perkins: 1545 lb (701 kg) Deutz: 1655 lb (751 kg)
Big Blue 500 CC/CV		20–600 A 14–40 V	500 A at 40 V (20 kW),* 100% Duty Cycle 550 A at 42 V (23.1 kW), 60% Duty Cycle 600 A at 34 V (20.4 kW), 40% Duty Cycle				Perkins: 1565 lb (710 kg) Deutz: 1695 lb (769 kg)

*NEMA EW1 (ANSI C87.1) Class (1) output ratings. **Additional 7 in (178 mm) to top of exhaust. ***Additional 190 lb (86 kg) when fuel tank is full.

CSA certification by Canadian Standards Association.

Big Blue 400 and 500 CC/CV Control Panel

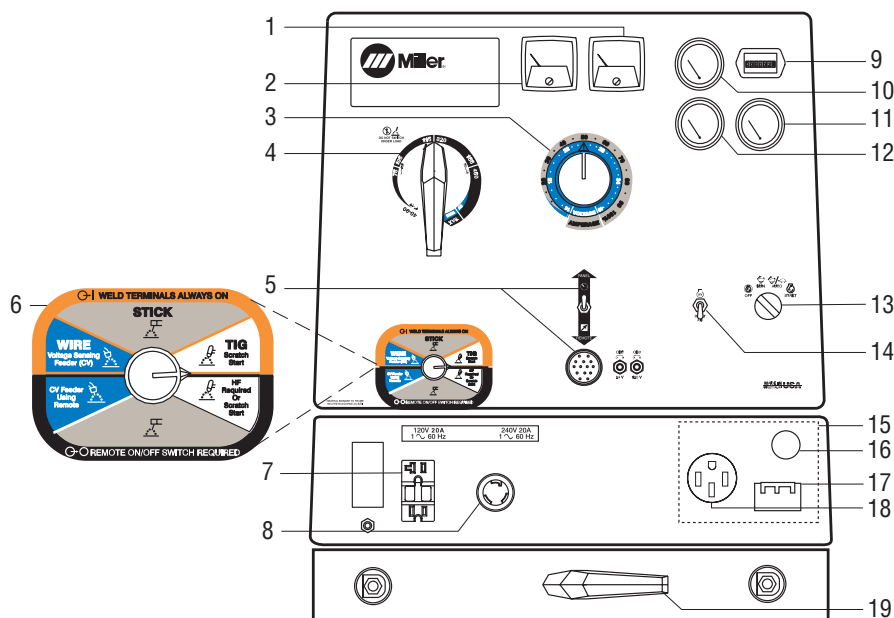

1. DC Ammeter
2. DC Voltmeter
3. Amperage/Voltage Adjust Control
4. Amperage Range Switch
5. Amperage/Voltage Adjust Switch and Remote Amperage/Voltage Adjust Receptacle
6. Process/Contactor Selector Switch
7. 120 VAC, 20 A GFCI Duplex Receptacle
8. 240 VAC, 30 A TwistLock Receptacle (NEMA L6-30)
9. Engine Hour Meter
10. Engine Oil Pressure Gauge
11. Fuel Gauge
12. Engine Coolant Temperature Gauge
13. Engine Control Switch
14. Starting Aid Switch
15. 3-Phase Power Generator Option
16. Strain Relief
17. 50 A, 3-Phase Circuit Breaker
18. 50 A, 120/240 V Receptacle (NEMA 14-50)
19. Polarity Switch*

*Optional.

Additional Features

One MIG welding range allows precise voltage control for welding with .023–.120 in (0.6–3.2 mm) wires.

A multi-colored **process selector control** allows quick and easy process changes without having to use multiple switches.

Solid-state control provides enhanced arc characteristics that include more dig in the Stick mode with smoother and lower amperage in the TIG mode. Extreme conditions will not cause the output to change, eliminating the need to periodically turn the heat up.

The rugged solid-state control board is housed in a **sealed vault**. The vault's sealed connections are made through watertight plugs that make this component impenetrable to dust and moisture.

14-pin remote control allows precise adjustment of amperage or voltage, along with contactor control, without walking back to the machine.

Big Blue 400 and 500 CC Performance Data

**400 CC
VOLT/AMP CURVES – STICK MODE**

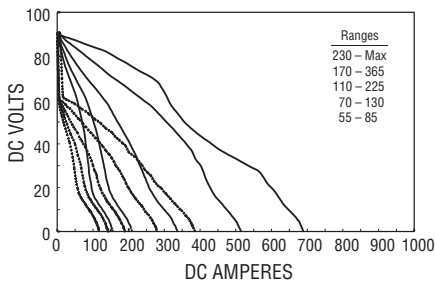

**500 CC
VOLT/AMP CURVES – STICK MODE**

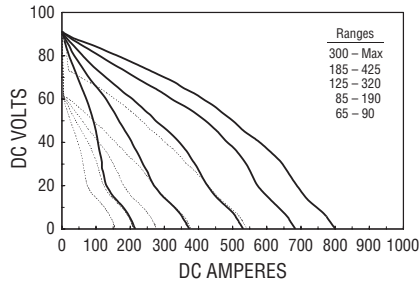

GENERATOR POWER CURVE

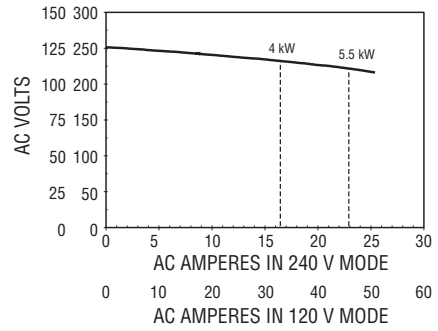

FUEL CONSUMPTION CURVE

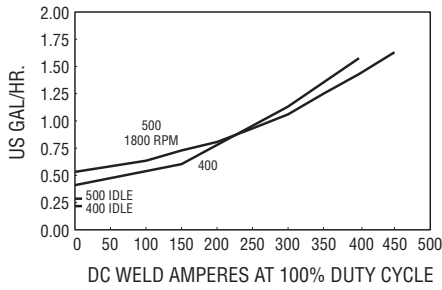

DUTY CYCLE CURVE

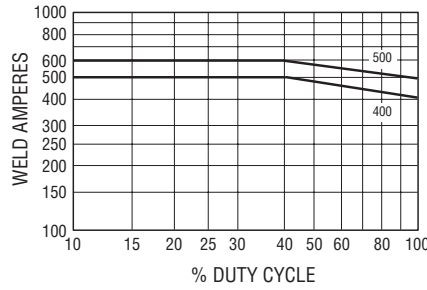

Big Blue 400 and 500 CC/CV Performance Data

**400 CC/CV
VOLT/AMP CURVES – STICK MODE**

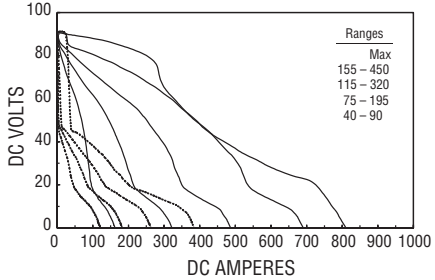

**500 CC/CV
VOLT/AMP CURVES – STICK MODE**

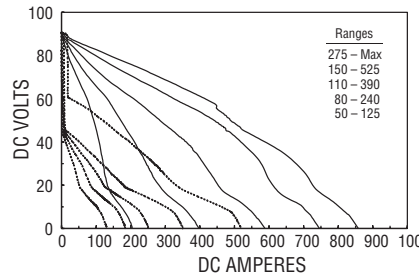

**3-PHASE GENERATOR
POWER CURVE**

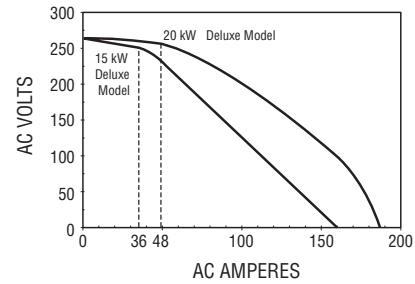

**400 CC/CV
VOLT/AMP CURVES – MIG MODE**

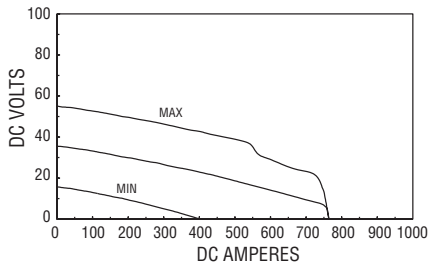

**500 CC/CV
VOLT/AMP CURVES – MIG MODE**

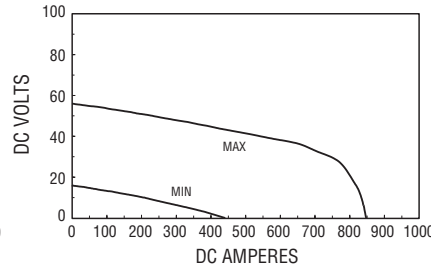

DUTY CYCLE CURVE

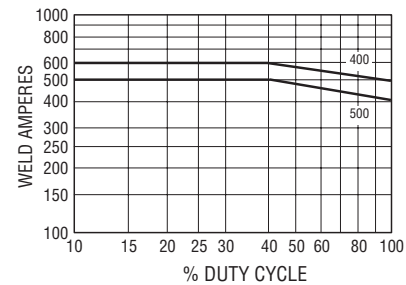

**400 CC/CV
VOLT/AMP CURVES – TIG MODE**

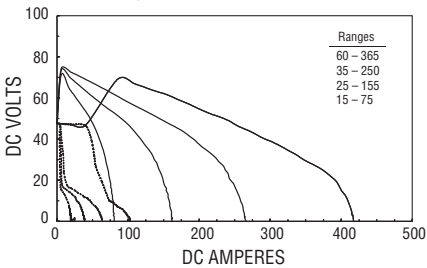

**500 CC/CV
VOLT/AMP CURVES – TIG MODE**

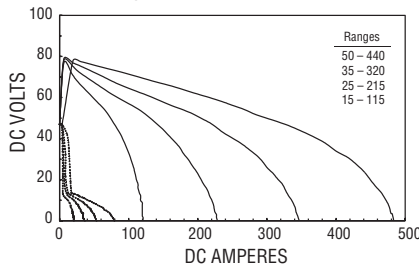

Engine Specifications (Subject to change without notice.)

Model	Engine Brand	Features	HP	Type	Engine Speeds (RPM)	Capacities	Automatic Engine Shutdowns
Big Blue 400	Perkins 404.22	Tier II, EPA-certified, indirect-injected, liquid-cooled engine with full load sound levels of 73.2 dB @ 7 m (98 Lwa) . Right-side service access with service intervals of 500 hours for oil and filters .	33	4-cylinder, industrial, liquid-cooled diesel	Weld: 1800 Idle: 1235*	Fuel: 25 gal (95 L) Oil: 9 qt (8.5 L) Coolant: 9 qt (8.5 L)	Oil pressure, coolant temp
	Deutz F3L2011	Tier II, EPA-certified, direct-injected, air/oil-cooled engine with full load sound levels of 76.8 dB @ 7 m (101.7 Lwa) . Right-side service access with service intervals of 1000 hours for oil and filters . Approved underground operation with the purchase of a MSHA (30 CFR part 7) certificate.	35	3-cylinder, industrial, air/oil-cooled diesel	Weld: 1800 Idle: 1235*	Fuel: 25 gal (95 L) Oil: 6.2 qt (5.9 L) Coolant: Integrated oil	Oil pressure, oil temperature
Big Blue 500	Perkins 404.22T	Tier II, EPA-certified, turbo-charged, direct-injected, liquid-cooled engine with full load sound levels of 73.2 dB @ 7 m (98 Lwa) . Right-side service access with service intervals of 500 hours for oil and filters .	47	4-cylinder, industrial, liquid-cooled diesel	Weld: 1800 Idle: 1235*	Fuel: 25 gal (95 L) Oil: 6.5 qt (6.2 L) Coolant: 9 qt (8.5 L)	Oil pressure, coolant temp
	Deutz F4L2011	Tier II, EPA-certified, direct-injected, air/oil-cooled engine with full load sound levels of 76 dB @ 7 m (101 Lwa) . Right-side service access with service intervals of 1000 hours for oil and filters . Approved underground operation with the purchase of a MSHA (30 CFR part 7) certificate.	47	4-cylinder, industrial, air/oil-cooled diesel	Weld: 1800 Idle: 1235*	Fuel: 25 gal (95 L) Oil: 9 qt (8.5 L) Coolant: Integrated oil	Oil pressure, oil temperature

*Optional on select models.

Genuine Miller Options

Weld Ammeter and Voltmeter Kit

#195 131 Field

Panel-mounted analog meters monitor welding output.

Installation time: 35 minutes

Battery Voltage Gauge

#195 454 Field

Monitors battery charging circuit.

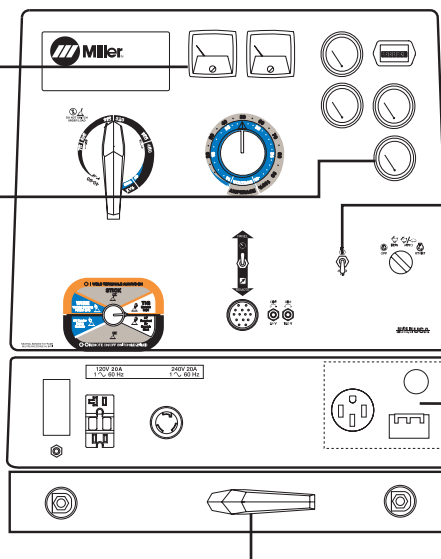

Cold Weather Starting Aid Kit

Note: Perkins 404.22 models come standard with glow plugs.

#195 056 Field

Perkins. 120 volt block heater.

#195 307 Field

Deutz F3L2011/ F4L2011. 12 volt intake manifold heater.

#195 087 Field

Deutz F3L2011/F4L2011. 120 volt oil pan heater.

3-Phase Power Generator Factory

(Deluxe CC/CV model only)

For Big Blue 400 CC/CV. 15,000 watts.

For Big Blue 500 CC/CV. 20,000 watts.

Adds three-phase, 240 V power to CC/CV units. 12 kW, 120/240 V single-phase power from a 50 amp receptacle. Optimum kW performance achieved while not welding. This option also includes a 50 amp on/off circuit breaker for both single- and three-phase power, and a strain relief for hard wiring into the unit.

Note: Available as factory option. See Ordering Information on back page.

Polarity Reversing Switch Kit

#043 942 Field

Changes DC polarity without the use of tools.

Installation time: 35 minutes

Genuine Miller Accessories

Remote Controls (CC model only)



RHC-3GD34A Remote Hand Control #041 122

Allows for precise adjustment of amperage. Includes 20 ft (6 m) cord.

Remote Controls (CC/CV models)



RHC-14 Hand Control #129 340

Miniature hand control for remote current and contactor control. Dimensions: 4 x 4 x 3-1/4 in (102 x 102 x 82 mm). Includes 20 ft (6 m) cord and 14-pin plug.



RCCS-14 Remote Contactor and Current Control #043 688

Up-and-down rotary-motion fingertip control fastens to TIG torch using two Velcro® straps. Includes 28 ft (8.5 m) control cord.



RFCS-14 HD Foot Control #194 744

Foot pedal provides remote current and contactor control. Includes 20 ft (6 m) cord and 14-pin plug.



RMLS-14 #129 337

Fingertip momentary- and maintained-contact rocker switch for contactor control. Push forward for maintained contact and back for momentary contact. Includes 20 ft (6 m) cord and 14-pin plug.

Extension Cords for 14-Pin Remote Controls

#122 973 25 ft (7.6 m)

#122 974 50 ft (15.2 m)

#122 975 75 ft (22.9 m)

TIG (GTAW) Welding



HF-251 Series

#042 388

HF-251D-1,
115 VAC

#042 387

HF-251D-2,
230 VAC

High-frequency arc starter and stabilizer. See Accessory Lit. Index No. AY/5.0.

MIG (GMAW)/Flux Cored (FCAW) Welding



SuitCase™ 8VS Wire Feeder #194 890

SuitCase™ X-TREME™ 12VS Wire Feeder

#195 500

Lightweight, portable, voltage-sensing wire feeders include secondary contactor and gas valve. Require drive roll kit. See Lit. Index No. M/6.4, M/6.41.

Stick (SMAW) Welding



No. 2/0 Stick Welding Accessory Kits

#173 851

50 ft (15 m) No. 2/0 electrode cable with electrode holder and 50 ft (15 m) No. 2/0 work cable with work clamp. 350 A at 100% duty cycle.

#043 952

100 ft (30.5 m) No. 2/0 electrode cable with electrode holder and 50 ft (15 m) No. 2/0 work cable with work clamp. 300 A at 100% duty cycle.



Lockable Fuel Cap Flame Arrestor Kit Green

#043 947 Field

Fuel cap can be padlocked to prevent vandalism. A built-in flame arrestor prevents flames or sparks from entering the fuel tank.

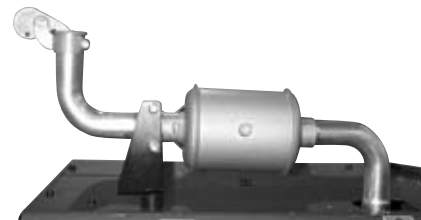

Spark Arrestor Muffler Kit

#195 012 Field

Prevents particles from leaving the muffler that could potentially start a fire. Mandatory when operating on California grasslands, brush, or forest-covered land, and in all National Forests. For other areas, check your state and local laws. Meets US Forest Service standard 5100-1B.



Vandalism Lockout Kit

#195 118 Field

Lockable hinged steel panels cover and protect name plate gauges and ignition switch (padlock included). Also includes engine compartment door lock and key.

Genuine Miller Accessories (Continued)



Cable Holder #043 946
Saddle-bag-style cable holder. Convenient wrap-around storage of coiled cable for transportation. Stores 100 ft of 2/0 cable on each side.

Note: For best results do not weld when cable is coiled! Canvas cover cannot be used with cable holder.



Roll Cage/Drip Pan #194 918 Field Heavy-duty galvanized steel structure designed to protect the machine. The roll cage meets

offshore oil platform requirements with a drip pan and drain plug along with a heavy-duty lift eye.



Canvas Cover (Blue) #194 683 Field Attractive, waterproof canvas cover resists stains and mildew,

and protects the finish of your welder.

Note: Canvas cover cannot be used with cable holder.

Trailers and Hitches (For both models.)



4 West Four-Wheel Steerable Off-Road Trailer #042 801

A heavy-duty 2570 lb (1166 kg) capacity trailer designed for use in mines, quarries, and other rough terrain. Has narrow 22 ft (6.7 m) turning radius. Includes 3 in lunette eye, universal hitch and safety chains.

Note: Trailer is shipped unassembled.



HWY-224 Trailer #043 805

A 2650 lb (1202 kg) capacity highway trailer. Welded steel tubing frame, heavy-duty axle with roller bearing hubs and leaf-spring suspension. The HWY-224 comes with jack stand, 2 in (50 mm) ball hitch, fenders and lights.

Note: Trailer is shipped unassembled.

OFR-224 Trailer #043 802

A 2650 lb (1202 kg) capacity off road trailer. Welded steel tubing frame, heavy-duty axle with roller bearing hubs and leaf spring suspension. The OFR-224 comes with jack stand and 2 in (50 mm) ball hitch.

Note: Trailer is shipped unassembled.

Lunette Eye 2-1/2 in (64 mm) #043 824

For use with both 224 trailers.

Cable Tree #043 826

Provides an area to conveniently wrap weld cables and extension cords. Works on all 224 and 430 trailers.



HWY-430 Tandem Axle Trailer #043 806

Smooth riding with 3750 lb (1701 kg) capacity. Includes: adjustable hitch for level operation, a hand operated parking brake, a self-actuating hydraulic brake system and a break-away device to lock brakes if the trailer comes loose. It also includes jack stand, fenders and lights. (Hitch must be ordered separately.)

Note: Some assembly required.

Ball Hitch 2 in (50 mm) #043 864

For use with the 430 trailer.

Lunette Eye 3 in (76 mm) #043 863

For use with the 430 trailer.

Trailer Specifications (Subject to change without notice.)

Model	Gross Axle Weight Rating	Gross Vehicle Weight Rating	Net Payload	Height of Bed	Road Clearance	Track (Center to center of tires)	Standard Tires (Standard rating or P-size rating)	Dimensions	Net Weight
4 West	2000 lb/axle (907 kg/axle)	3000 lb (1361 kg)	2570 lb (1166 kg)	21-1/4 in (540 mm)	8 in (203 mm)	55-1/4 in (1403 mm)	B78-13	Length: 91 in (2311 mm)** Width: 61-1/4 in (1556 mm)	430 lb (195 kg)
HWY-224 OFR-224	3500 lb (1588 kg)	2960 lb (1343 kg)	2650 lb (1202 kg)	18-1/2 in (470 mm)	7-1/2 in (191 mm)	52 in (1321 mm)	B78-13B	Length: 122-1/2 in (3112 mm) Width: HWY-61 in (1549 mm)* OFR-58-1/2 in (1486 mm)	355 lb (161 kg)
HWY-430	2200 lb/axle (998 kg/axle)	4280 lb (1941 kg)	3750 lb (1701 kg)	19-1/4 in (489 mm)	8-1/2 in (216 mm)	52 in (1321 mm)	B78-13B	Length: 156-1/2 in (3975 mm) Width: 61 in (1549 mm)*	530 lb (240 kg)

* Width at outside of fenders. ** Does not include tongue.

Ordering Information

Equipment and Factory Options	Stock No.	Description	Qty.	Price
Big Blue® 400 CC	#907 173 #907 175	Deutz F3L2011 with engine gauges Perkins 404.22 with engine gauges		
Big Blue® 400 CC/CV Deluxe Model Deluxe Model	#907 327 #907 329	Deutz F3L2011 with engine gauges, automatic idle, weld meters, 15 kW Perkins 404.22 with engine gauges, automatic idle, weld meters, 15 kW		
Big Blue® 500 CC	#907 181	Deutz F4L2011 with engine gauges		
Big Blue® 500 CC/CV Deluxe Model Deluxe Model	#907 331 #907 333	Deutz F4L2011 with engine gauges, automatic idle, weld meters, 20 kW Perkins 404.22T with engine gauges, automatic idle, weld meters, 20 kW		
Field Kit Accessories				
Weld Ammeter and Voltmeter	#195 131	For all models, analog welding meters		
Polarity Reversing Switch		#043 942 For all models, DC polarity switch		
Cold Weather Starting Aids	#195 056 #195 307 #195 087	Perkins, 120 volt block heater Deutz F3L2011 and F4L2011, 12 volt intake manifold heater Deutz F3L2011 and F4L2011, 120 volt oil pan heater		
Battery Voltmeter	#195 454	For all models, analog		
Lockable Fuel Cap Flame Arrestor	#043 947	For all models, padlock not included		
Spark Arrestor Muffler	#195 012	For all models, horizontal externally mounted		
Vandalism Lockout Kit	#195 118	For all models, lockable front control panel and engine compartment		
Cable Holder	#043 946	For all models, stores up to 200 ft of 2/0 weld cable		
Roll Cage/Drip Pan	#194 918	For all models, meets offshore oil platform requirements		
Protective Cover	#194 683	For all models, will not work with cable holder accessory		
Remote Controls				
RHC-3GD34A	#041 122	CC models only, hand control		
RHC-14	#129 340	CC/CV models only, amperage or voltage control		
RCCS-14	#043 688	CC/CV models only, fingertip control		
RFCS-14 HD	#194 744	CC/CV models only, foot control		
RMLS-14	#129 337	CC/CV models only, momentary and maintained contact switch		
Remote Control Extension Cords		See page 6		
TIG Accessories				
High Frequency Arc Starters	#042 388 #042 387	HF-251D-1, 115 VAC. See Lit. Index No. AY/5.0 HF-251D-2, 230 VAC. See Lit. Index No. AY/5.0		
MIG/Flux Cored Accessories				
SuitCase™ 8VS/X-TREME™ 12VS	#194 890/#195 500	See Lit. Index No. M/6.4 and M/6.41		
Stick Accessories				
Accessory Kits	#173 851 #043 952	2/0, 350 A, 100% duty cycle, 50 ft (15 m) stinger, 50 ft (15 m) work clamp 2/0, 300 A, 100% duty cycle, 100 ft (30.5 m) stinger, 50 ft (15 m) work clamp		
Trailers and Hitches				
HWY-224 Trailer	#043 805	Trailer with lights, fenders and 2 in ball hitch		
OFR-224 Trailer	#043 802	Trailer with 2 in ball hitch		
Lunette Eye, 2-1/2 in	#043 824	Replaces the 2 in ball hitch on the HWY-224 or OFR-224		
Cable Tree	#043 826	Trailer mounted cable holder for HWY-224, OFR-224 or HWY-430		
HWY-430 Trailer	#043 806	Hitch required		
Ball Hitch, 2 in	#043 864	For HWY-430 only		
Lunette Eye, 3 in	#043 863	For HWY-430 only		
4-West Trailer	#042 801	4 wheel steerable implement trailer		

Date:

Total Quoted Price:



Distributed by: