

Weldmatic 175 **[internal wirefeeder]** Operators Manual



Weldmatic 175 MIG welder
Model No. CP122-1, Iss A
07/07



Welding Industries of Australia

An ITW Company

ABN 18 004 547 111

Telephone: 1300 300 884

Facsimile: 1300 301 884

Email: Info@welding.com.au

www.welding.com.au

Contents

Section	General Information	Page
	Safe Practices	2
1	Introduction	5
2	Receiving	5
3	Specifications	6
4	Controls	7
5	Installation	8
6	Normal Welding Sequence	10
7	Basic Welding Information	10
8	General Maintenance	15
9	External Trouble Shooting	16
10	Service Information	18
	10.1 PWA-006 Control Board	18
	10.2 Circuit Diagram	19
11	Assembly and Parts Lists	
	11.1 Power Source	20
	11.2 Wirefeed assembly	22
	11.3 Gun and Cable Assembly	23
12	Warranty information	25



Read First

The information contained in this manual is set out to enable you to properly maintain your new equipment and ensure that you obtain maximum operating efficiency.

Please ensure that this information is kept in a safe place for ready reference when required at any future time.

When ordering spare parts, please quote the model and serial number of the power source and part number of the item required. All relevant numbers are shown in lists contained in this manual. Failure to supply this information may result in unnecessary delays in supplying the correct parts.

Safety

Before this equipment is put into operation, please read the Safe Practices section of this manual. This will help to avoid possible injury due to misuse or improper welding applications.

Plastic Handles on Power Source

Please note that the handles fitted to the Weldmatic 175 power source are intended for carrying the equipment by hand only.

DO NOT use these handles for suspending or mounting the power source in any other manner.

Safe practices when using welding equipment

These notes are provided in the interests of improving operator safety. They should be considered only as a basic guide to Safe Working Habits. A full list of Standards pertaining to industry is available from the Standards Association of Australia, also various State Electricity Authorities, Departments of Labour and Industry or Mines Department and other Local Health or Safety Inspection Authorities may have additional requirements. Australian Standard AS1674.2 provides a comprehensive guide to safe practices in welding.

Eye protection

NEVER LOOK AT AN ARC WITHOUT PROTECTION. Wear a helmet with safety goggles or glasses with side shields underneath, with appropriate filter lenses protected by clear cover lens. This is a **MUST** for welding, cutting, and chipping to protect the eyes from radiant energy and flying metal. Replace the cover lens when broken, pitted, or spattered.

Recommended shade filter lens

Amps	TIG	MMAW	MIG	Pulsed MIG
0-100	10	9	10	12-13
100-150	11	10	10	12-13
150-200	12	10-11	11-12	12-13
200-300	13	11	12-13	12-13
300-400	14	12	13	14
400-500	—	13	14	14
500 +	—	—	14	14

Burn protection

The welding arc is intense and visibly bright. Its radiation can damage eyes, penetrate light-weight clothing, reflect from light-coloured surfaces, and burn the skin and eyes. Burns resulting from gas-shielded arcs resemble acute sunburn, but can be more severe and painful.

Wear protective clothing - leather or heat resistant gloves, hat, and safety-toe boots. Button shirt collar and pocket flaps, and wear cuffless trousers to avoid entry of sparks and slag.

Avoid oily or greasy clothing. A spark may ignite them. Hot metal such as electrode stubs and work pieces should never be handled without gloves.

Ear plugs should be worn when welding in overhead positions or in a confined space. A hard hat should be worn when others are working overhead.

Flammable hair preparations should not be used by persons intending to weld or cut.

Toxic fumes

Adequate ventilation with air is essential. Severe discomfort, illness or death can result from fumes, vapours, heat, or oxygen depletion that welding or cutting may produce. **NEVER** ventilate with oxygen.

Lead, cadmium, zinc, mercury, and beryllium bearing and similar materials when welded or cut may produce harmful concentrations of toxic fumes. Adequate local exhaust ventilation must be used, or each person in the area as well as the operator must wear an air-supplied respirator. For beryllium, both must be used.

Metals coated with or containing materials that emit fumes should not be heated unless

coating is removed from the work surface, the area is well ventilated, or the operator wears an air-supplied respirator.

Work in a confined space only while it is being ventilated and, if necessary, while wearing air-supplied respirator.

Vapours from chlorinated solvents can be decomposed by the heat of the arc (or flame) to form phosgene, a highly toxic gas, and lung and eye irritating products. The ultra-violet (radiant) energy of the arc can also decompose trichlorethylene and perchlorethylene vapours to form phosgene. Do not weld or cut where solvent vapours can be drawn into the welding or cutting atmosphere or where the radiant energy can penetrate to atmospheres containing even minute amounts of trichlorethylene or perchlorethylene.

Fire and explosion prevention

Be aware that flying sparks or falling slag can pass through cracks, along pipes, through windows or doors, and through wall or floor openings, out of sight of the operator. Sparks and slag can travel up to 10 metres from the arc.

Keep equipment clean and operable, free of oil, grease, and (in electrical parts) of metallic particles that can cause short circuits.

If combustibles are present in the work area, do NOT weld or cut. Move the work if practicable, to an area free of combustibles. Avoid paint spray rooms, dip tanks, storage areas, ventilators. If the work can not be moved, move combustibles at least 10 metres away out of reach of sparks and heat; or protect against ignition with suitable and snug-fitting fire-resistant covers or shields.

Walls touching combustibles on opposite sides should not be welded on or cut. Walls, ceilings, and floor near work should be protected by heat-resistant covers or shields.

Walls touching combustibles on opposite sides should not be welded on or cut. Walls, ceilings, and floor near work should be protected by heat-resistant covers or shields.

A person acting as Fire Watcher must be standing by with suitable fire extinguishing equipment during and for some time after welding or cutting if;

- Combustibles (including building construction) are within 10 metres.
- Combustibles are further than 10 metres but can be ignited by sparks.
- Openings (concealed or visible) in floors or walls within 10 metres may expose combustibles to sparks.
- Combustibles adjacent to walls, ceilings, roofs, or metal partitions can be ignited by radiant or conducted heat.

After work is done, check that area is free of sparks, glowing embers, and flames.

A tank or drum which has contained combustibles can produce flammable vapours when heated. Such a container must never be welded on or cut, unless it has first been cleaned as described in AS.1674-2. This includes a thorough steam or caustic cleaning (or a solvent or water washing, depending on the combustible's solubility), followed by purging and inerting with nitrogen or carbon dioxide, and using protective equipment as recommended in AS.1674-2. Water-filling just below working level may substitute for inerting.

Hollow castings or containers must be vented before welding or cutting. They can explode. Never weld or cut where the air may contain flammable dust, gas, or liquid vapours.

Shock Prevention

Exposed conductors or other bare metal in the welding circuit, or ungrounded electrically alive equipment can fatally shock a person whose body becomes a conductor. Ensure that the equipment is correctly connected and earthed. If unsure have the equipment installed by a qualified electrician. On mobile or portable equipment, regularly inspect condition of trailing power leads and connecting plugs. Repair or replace damaged leads.

Fully insulated electrode holders should be used. Do not use holders with protruding screws. Fully insulated lock-type connectors should be used to join welding cable lengths.

Terminals and other exposed parts of electrical units should have insulated knobs or covers secured before operation.

1 Introduction

Gas Metal Arc Welding (G.M.A.W.) is an arc welding process where a consumable wire is fed by motor driven feed rolls to a welding gun, and where welding current is supplied from the welding power source. The welding arc is struck between the work piece and the end of the wire, which melts into the weld pool. The arc and the weld pool are both shielded by gas flow from the gun, or in the case of "self shielded" wires, by gases generated by the wire core.

The process is very versatile in that by selection of the correct wire composition, diameter and shielding gas, it can be used for applications ranging from sheet-metal to heavy plate, and metals ranging from carbon steel to aluminium alloys.

The Weldmatic 175 has been designed to be used with consumable wires in the range from 0.6mm to 1.2mm diameter. The smaller wire sizes are used when welding at lower currents, such as sheet-metal applications. Increasing the wire diameter permits higher welding currents to be selected.

A common application of G.M.A.W. is for welding Mild Steel. In this application, a Mild Steel solid consumable wire such as AUSTMIG ES6 is used with a shielding gas of Carbon Dioxide, or Argon mixed with Carbon Dioxide. Alternatively, Flux-cored consumable wires are available in both gas shielded, and 'gasless' self shielding types.

Stainless steel and Aluminium can be welded with G.M.A.W. using the correct consumable wire and shielding gas.

The Weldmatic 175 wirefeeder has been designed to feed a range of hard, soft, and flux-cored wires for the G.M.A.W. process. A compact motor with integral gear box is coupled to a two roll drive assembly forming the basic component of the wirefeeder. The motor is controlled by an electronic speed control which provides speed regulation.

2 Receiving

Check the equipment received against the shipping invoice to make sure the shipment is complete and undamaged. If any damage has occurred in transit, please immediately notify your supplier.

3 Specifications

Manufactured to Australian Standard AS60974.1.

Primary Voltage

240 Vac, 50/60 Hz

Rated Primary Current

12 Amps

Maximum Primary Current

28 Amps

Recommended Generator kVA

6.7 kVA

Rated Output @ 40°C

Duty cycle based on 10 minute cycle time
175 Amp, 22.8 V, 15% duty
67 Amp, 18 V, 100% duty

Welding Current

35 - 175 Amps

Open Circuit Voltage

19 - 40 V

Shipping weight

45 kg

Mains Circuit Breaker Rating

16 Amps

Supply plug

15 Amp

Fitted Supply Cable

30/0.25 Three Core, Heavy Duty PVC

If the supply cable is damaged it must be replaced by the manufacturer, their service agent or a similarly qualified person.

Cooling

Fan cooled, air drawn in through rear grille.

Insulation

Class H, 140°C Rise

Spool Sizes

1 kg, 5 kg

Wirespeed Range

0 - 160 RPM (0 - 15 Metres per min.)

Wire Size Range

0.6mm - 0.9mm diameter (solid wire)
0.8mm - 1.2mm diameter (cored wire)

4 Controls



Fig 1 Power Source Controls

1 Wire Speed Control

This control provides adjustment of the wirefeed speed. Rotating the dial in a clockwise direction will increase the wirefeed speed, thereby increasing the welding current.

Refer to the **Weld Setting Chart** in Section 7 of this manual for information on setting these controls to obtain the intended welding current. This chart is also located inside the wire-spool enclosure cover

2 Euro Gun/Cable Connector.

3 Coarse Voltage Control

This switch provides Coarse adjustment of the output welding voltage over three ranges.

4 Over Temperature Indicator

Lights up if the unit over heats

5 Fine Voltage Control

This switch provides Fine adjustment of the output welding voltage over three ranges.

Note: Minimum welding voltage is obtained with Coarse A and Fine 1 selected. Maximum welding voltage is obtained with Coarse C and Fine 3 selected.

Do not operate the Voltage Control switches during welding

6 Standby/Operate Switch

7 Positive Welding Output Terminal

8 Negative Welding Output Terminal

5 Installation

Connection to Electrical Mains Power Supply

The Weldmatic 175 is factory fitted with a 3 metre, 3 core 30/0.25 Heavy Duty PVC mains power supply cable with moulded 3 pin, 15 Amp, Single Phase plug.

A 15 Amp plug and socket is recognisable by a wide Earth pin. Power Supply authorities require that equipment fitted with a 15 Amp plug shall ONLY be connected to a 240 Volt, 15 Amp power point. DO NOT modify the plug.

The minimum capacity of the mains wiring and power outlet supplying a welder is selected according to the effective primary current of the equipment. The effective primary current for the Weldmatic 175 is 12 Amps.

The minimum recommended mains circuit breaker rating for a Weldmatic 175 is 16 Amps. **Note :** Due to normal variations of sensitivity, the tripping time of some 16A circuit breakers may limit the duty cycle available from the Weldmatic 175. A higher rated circuit breaker can be selected, but the mains wiring capacity must be rated to suit.

The current rating of the mains cable depends on cable size and method of installation. Refer to AS/NZS 3008.1, Table 9.

If it becomes necessary to replace the mains flexible supply cable, use only cable with correct current rating. Access to the supply terminals is gained by removing the power source side panels.

The replacement cable must be fitted and retained in the same manner as the original.

Output Voltage Polarity

The design of the Weldmatic 175 allows selection of the output voltage polarity.

Positive Wire

G.M.A.W. with solid consumable wires is carried out with the work piece Negative and the welding wire Positive.

To setup for this condition, connect the 'WORK' lead plug into the (-) output socket on the Power Source, and the 'WELDING' lead from the power source into the (+) socket, as in Figure 2.



Fig 2 Positive Wire

Negative Wire

Some 'self-shielded' flux cored consumable wires are operated with the work piece Positive and the consumable wire Negative. Refer to the manufacturers data for the particular consumable wire to be used.

To setup for this condition, connect the 'WORK' lead plug into the (+) output socket on the Power Source, and the 'WELDING' lead from the power source into the (-) socket, as in Figure 3.



Fig 3 Negative Wire

Fitting the gas cylinder

Place the gas cylinder on the tray at the rear of the optional welder trolley (if using). Retain the cylinder with the chain provided.

Fit the gas regulator to the cylinder. DO NOT apply grease or oil to these joints.

Fit the end of the gas inlet hose from the back of the power source to the connector supplied with the gas regulator, and secure with the clamp also supplied.

Fitting The Gun and Cable Assembly

The supplied gun/cable assembly is equipped with a 'Euro' wirefeeder connector which incorporates all required connection points for welding current, shielding gas and gun switch control.

To attach the gun/cable assembly to the wirefeeder mechanism, engage the mating parts of the male and female Euro connectors, then rotate the locking ring clockwise to firmly secure the connection.

Fitting the Consumable Wire

The quality of the consumable wire greatly affects how reliably a gas metal arc welder will operate. For best results when welding mild steel, we recommend quality WIA AUSTMIG ES6. Dirty, rusty or kinked wire will not feed smoothly through the gun cable and will cause erratic welding. Deposits from the wire will clog the gun cable liner requiring it to be replaced prematurely.

5 kg Spools

Place the spool of welding wire onto the spool holder. The location pin should mate with a hole provided on the wire spool body. Fit the spool retaining 'R' clip supplied. Check

the adjustment of the spool adjuster, which should be set to prevent over run of the wire spool at the end of a weld, without unduly loading the wirefeed motor.

1 kg Spools

Remove the adjuster knob, spring, washer and 5 kg spool holder. Leave the 5 kg spool holder in a safe place (ie inside the welder). Fit the 1kg wire spool directly onto the spool axle. Fit the washer, spring and adjuster knob and tighten the adjuster knob fully.

Feeding the Consumable Wire

At the wirefeed assembly, release the compression screw by swivelling it outwards. This allows the top roller arm to spring to the open position. The end of the welding wire can now be passed through the inlet guide, over the bottom driven roller, and into the output wire guide tube. Check that the drive roll groove is correct for the wire in use. The appropriate size is stamped on the visible side of the installed roller. Check also that the correct size contact tip is fitted at the gun end. Feed roller and tip details are shown in Section 11 of this manual.

Return the top roller arm to the closed position and adjust the compression screw to provide sufficient clamping of the drive roll to achieve constant wirefeed. Do not over tighten.

With the equipment energised, operate the gun switch to feed wire through the gun cable.

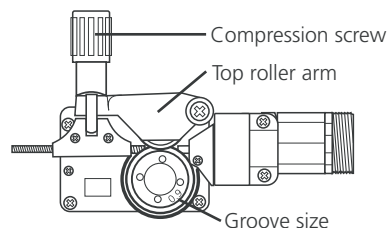

6 Normal Welding Sequence

Weld Start

Closing the welding gun switch initiates this sequence of events:

- The gas valve is energised and gas flow commences;
- The power source contactor is initiated. Welding voltage is applied between the work piece and the consumable wire.
- The wire drive motor is energised.
- The wire touches the work piece, and the arc is established.

Weld End

Releasing the gun switch initiates this sequence of events:

- The wire drive motor is de-energised, and is dynamically braked to a stop;
- The welding transformer is de-energised and welding current stops.
- The gas valve is de-energised and the flow of shielding gas ceases.

7 Basic Welding Information

Choice of Shielding Gas

The choice of shielding gas is largely determined by the consumable wire to be used. Many proprietary shielding gas mixtures are available.

The recommended shielding gases for use with the Weldmatic 175 are:

- Mild Steel Argon + 5 to 25% Carbon Dioxide;
- Aluminium Argon;
- Stainless Steel Argon + 1 to 2% Oxygen.

Consult your gas supplier if more specific information is required.

Shielding Gas Flow Rate

In G.M.A. welding, one function of the shielding gas is to protect the molten weld pool from the effects of oxygen in the atmosphere. Without this protection the weld deposit becomes 'honeycombed' in appearance, an effect which is described as weld porosity.

In draft-free conditions the gas flow rate required to give adequate protection is typically 10-12 litres/min. In situations where drafts cannot be avoided, it may be necessary to increase this rate up to 20 litres/min, and/or to provide screening of the work area.

Weld porosity can also be caused by air entering the gas stream through a damaged hose, loose gas connection, or from restriction in the nozzle, such as from excess build-up of spatter.

When welding aluminium, particular care must be taken with all aspects of shielding gas delivery and workpiece preparation in order to avoid weld porosity.

Weldmatic 175 Settings Chart

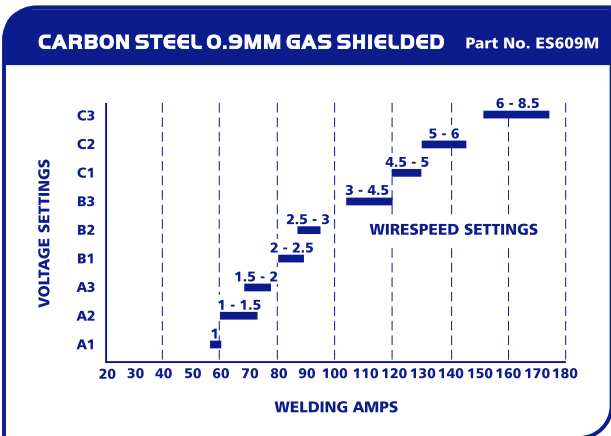
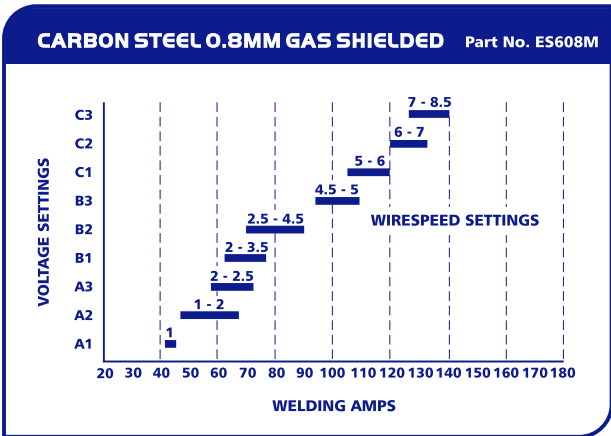
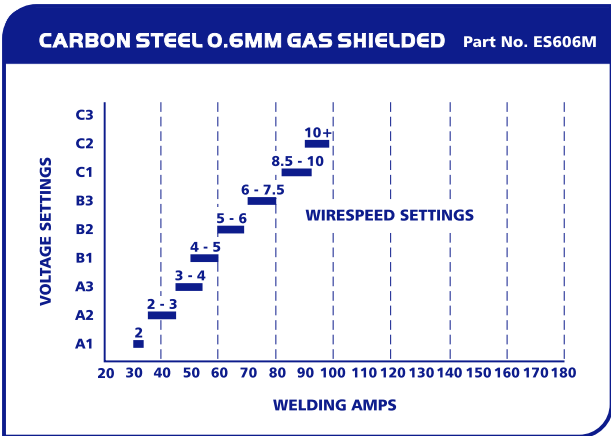
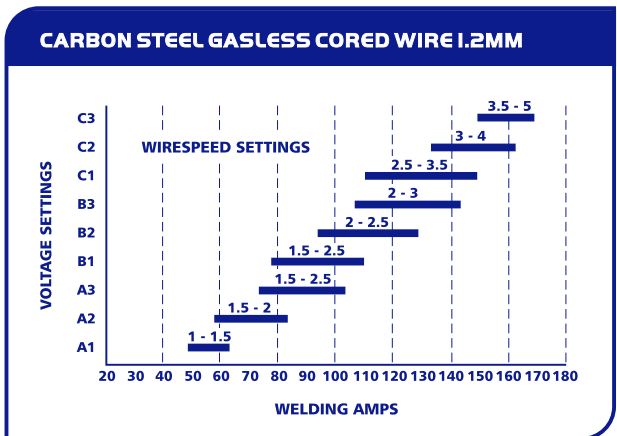
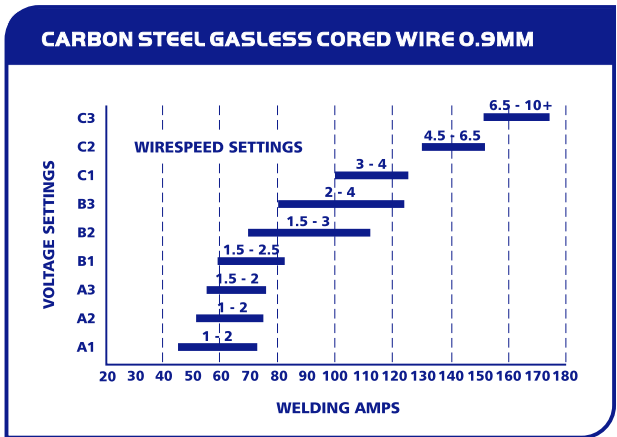

Fig 4 Weld Setting Charts

Weldmatic 175 Settings Chart (cont)



WELDING CONSUMABLES

Size	WIA Part No.
Carbon steel solid wires - 5 kg spool	See Above
Carbon steel gasless wires - 4.5 kg spool	
0.9mm	S222308-022
1.2mm	S222112-022
BERNARD contact tips	
0.6mm	BE7497
0.8mm	BE7488
0.9mm	BE7489
1.2mm	BE7490
Wire drive rollers	
0.6 + 0.8mm, Solid Wire	W26-0/8
0.8 + 0.9mm, Solid Wire (fitted)	W26-8/8
0.8 + 1.0mm, Solid Wire	W26-1/8
0.9 + 1.2mm, Solid Wire	W26-5/8
1.0 + 1.2mm, Aluminium Wire	W26-3/8
1.0 + 1.2mm, Flux Cored Wire	W26-7/8

Fig 4 Weld Setting Charts

Establishing a Weld Setting

Once the consumable wire type, wire size and shielding gas have been chosen, the two variables that are adjusted in order to obtain a the desired weld setting are;

- Wirefeed speed,
- Welding arc voltage.

The Weld Setting Charts in Figure 4 can be used to preset the machine for an approximate welding current. For each of the combinations of voltage control switch settings, there is a range of valid wirefeed settings.

The wirefeed speed determines the welding current; increasing the speed increases the current, and decreasing it decreases current.

The selected wirefeed speed must be matched with sufficient arc voltage; a speed increase requires an increase of arc voltage.

If the voltage is too low the wire will stub and stutter, and there will not be a steady arc. If the voltage is too high the arc will be long with metal transfer occurring as a series of large droplets.

Important: Do not operate the Voltage Control switches during welding.

The weld setting should be chosen to suit the application and the thickness of the metal to be welded. It is important to check that the deposited weld provides sufficient strength to suit the application.

A “good” weld will have the characteristics illustrated in Figure 5. The weld has penetrated into the parent metal, fusing the root of the joint where the two plates meet, and the weld blends smoothly into the side walls.

A “bad” weld is shown in Figure 6. The weld has not penetrated the joint root, and there is poor side wall fusion. This lack of fusion would normally be corrected by increasing

the arc voltage, or by increasing both wirefeed speed and arc voltage to achieve a higher current weld setting.

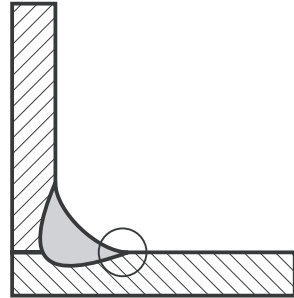

Fig 5 “Good” Weld

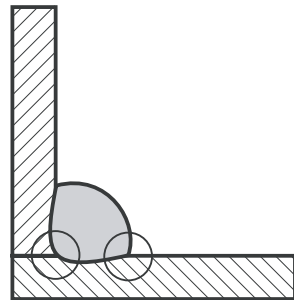

Fig 6 “Bad” Weld

Gun Position

For “down hand” fillet welding with gas shielded solid wires, the gun is normally positioned as shown in Figure 7a below, with the nozzle end pointing in the direction of travel.

For “down hand” fillet welding with gasless flux cored wires, the gun is normally positioned as shown in Figure 7b below, with the nozzle end pointing away from the direction of travel, referred to as ‘dragging’ the weld. Gasless flux cored wires should be

operated with approximately 15mm of wire 'stick-out' from the welding contact tip as shown in Figure 7c.

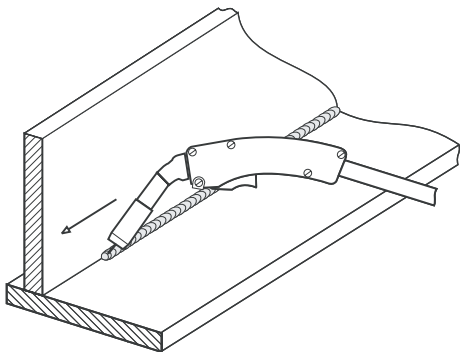

Fig 7a Gas Shielded Solid Wires

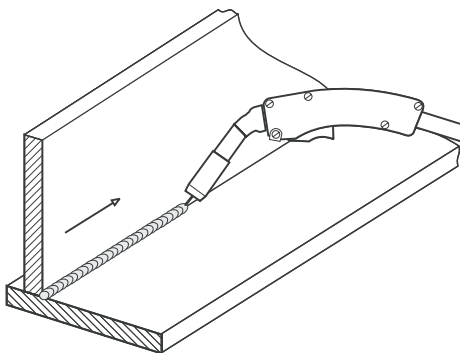

Fig 7b Gasless Flux Cored Wires

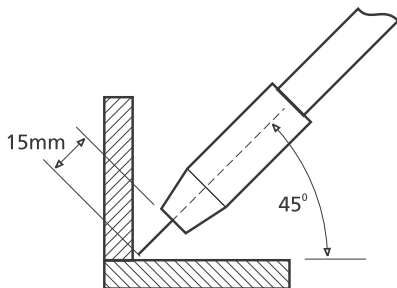

Fig 7c Wire Stickout for Gasless Welding

Duty Cycle

The term duty cycle indicates the percentage welding time available at the rated output current, for each 10 min period over 4 hours.

The Weldmatic 175 is rated 175 Amps, 15% duty cycle. If the machine is operated at a reduced welding current, a higher duty cycle is available. The diagram below illustrates the appropriate duty cycle rating for the range of welding currents available from the 175, and so allows the maximum welding time per 10 minute period to be determined.

The power source is protected by in built over temperature protection devices. These will operate if the machine is operated in excess of its current and duty cycle rating. If this occurs, the fan will continue to run, but the machine will not deliver welding current until the unit has cooled sufficiently.

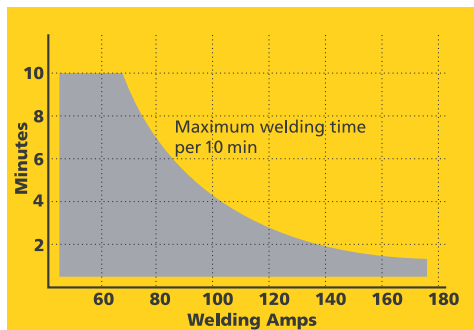

Fig 8 Duty Cycle Rating

8 General Maintenance

Before removing the equipment cover, ENSURE that the equipment is disconnected from the mains power supply. When the equipment is energised LETHAL VOLTAGES are present on the electrical components enclosed.

Dust

Care should be taken to prevent excessive build-up of dust and dirt within the welding power source. It is recommended that at regular intervals, according to the prevailing conditions, the equipment covers be removed and any accumulated dust be removed by the use of dry, low pressure compressed air, or a vacuum cleaner.

Wirefeed

In order to obtain the most satisfactory welding results from the G.M.A.W. process, the wirefeed must be smooth and constant. Most causes of erratic wirefeed can be cured by basic maintenance. Check that the:

- 1 Feed rolls are the correct size and type for the wire in use. Check also that the drive groove is aligned with the wire (refer page 9), and that the groove is not worn;
- 2 Gun cable liner is clear of dust and swarf build-up. When replacement becomes necessary, fit only the correct liner (see page 24). The build-up of dust can be minimised by regular purging of the liner with dry compressed air. This may be conveniently done each time the wire spool is replaced;
- 3 Welding tip is free of obstructions such as spatter build-up. Ream out the tip bore with a suitable size oxy-tip cleaner. Replace the welding tip as it becomes worn;
- 4 Feed roll pressure is not excessive. The pressure should be just sufficient to feed the wire evenly. Excessive pressure will deform the electrode wire and make feeding more difficult;
- 5 Consumable wire spool holder rotates smoothly and that the braking action is not excessive. The spool should only have sufficient braking to prevent over run when the motor stops. This also may be conveniently checked each time the wire is replenished;
- 7 Welding wire is straight and free of buckles or 'waviness'. To check, remove 2 or 3 metres of wire from the spool. Clamp one end in a vice or similar, then holding the other end pull the wire out straight. Look down the length of the wire, any buckles will be obvious. Buckled wire is extremely difficult to feed reliably and should be replaced;
- 8 Welding wire is free of surface rust. Replace if rust is evident.

9 External Trouble Shooting

If the following checks do not identify the fault condition, the equipment should be returned to a WIA Service agent. Phone 1300 300 884 for details of your nearest service agent.

9 External Trouble Shooting

Power source has no output and no wirefeed when gun switch is closed :

'OPERATE' switch is not illuminated

- 1 Check equipment is connected to a functional mains power outlet. Test outlet using a known working appliance.

'OPERATE' switch is illuminated

- 1 The gun switch circuit may be incomplete.
 - Check the gun switch for continuity with an ohm meter when the switch is pressed. Replace if faulty
 - Check the 2 pin receptacles in Euro adaptor are making contact with the mating pins from the gun Euro end.
- 2 Power source may have overheated.
 - The Weldmatic 175 welding power source incorporates an in-built over-temperature thermostat which will trip if the welding load exceeds the operating duty cycle. The 'OVERLOAD' light will be illuminated when the gun is switched on. The thermostat will reset automatically - do not switch the equipment off as the cooling fan will assist the resetting of the thermostat
 - If problem persists after the cool down period, call your WIA service agent.

Power source has low weld output

- 1 Check all electrical connections in the welding current circuit, including weld cable, work clamp and gun/cable assembly.

Circuit breaker trips during welding

- 1 Check the rating of the mains supply circuit breaker. The Weldmatic 175 should be supplied from a 16 Amp or larger circuit breaker.

Unsatisfactory Welding Performance and Results

Erratic arc characteristics caused by poor wirefeed

Erratic wirefeed is the MOST LIKELY cause of failure in all Gas Metal Arc Welding. It should therefore be the first point checked when problems occur.

- 1 Refer to the points in 'Wirefeed' in Section 8
- 2 Check if the consumable wire is slipping in the drive rolls. Replace the feed roll if it is the incorrect size or is worn
- 3 Check that gun cable liner is not too short and is fitted correctly. Refer to page 24 for fitting instructions.

Constant poor arc characteristics

Check that the:

- 1 Correct polarity has been selected for work and weld cables (refer page 8)
- 2 Shielding gas is correct for the consumable wire in use (refer page 10)
- 3 Welding circuit is making good electrical connection. Ensure that the work clamp is securely tightened onto the work piece so that good electrical contact is achieved

- 4 All connections in the external welding circuit are clean and tight. Problems may show as hot spots
- 5 Work piece surface is not contaminated. Water, oil, grease, galvanising, paint, or oxide layers can severely disturb the welding arc and result in a poor weld.

Porosity in weld caused by lack of shielding gas

- 1 Check that the correct gas flow rate has been set (refer page 10)
- 2 Check for leaks in the gas hose. Replace if leaking
- 3 Check for leaks in gun/cable assembly, eg. fractured gas hose, broken or missing 'O' rings. Replace as required
- 4 Check the gun nozzle is free from spatter and is firmly attached to the welding gun to ensure that no air is being drawn into the shielded area.

10 Service Information

The following information is intended for use by qualified service personnel. When the unit is energised LETHAL VOLTAGES are present on the electrical and electronic components. It is not intended that persons without suitable training and knowledge attempt to perform service tasks on the components of this welder.

Before removing the equipment cover, ENSURE that the equipment is disconnected from the mains power supply. When the equipment is energised LETHAL VOLTAGES are present on the electrical components enclosed.

10.1 PWA006 Control Board

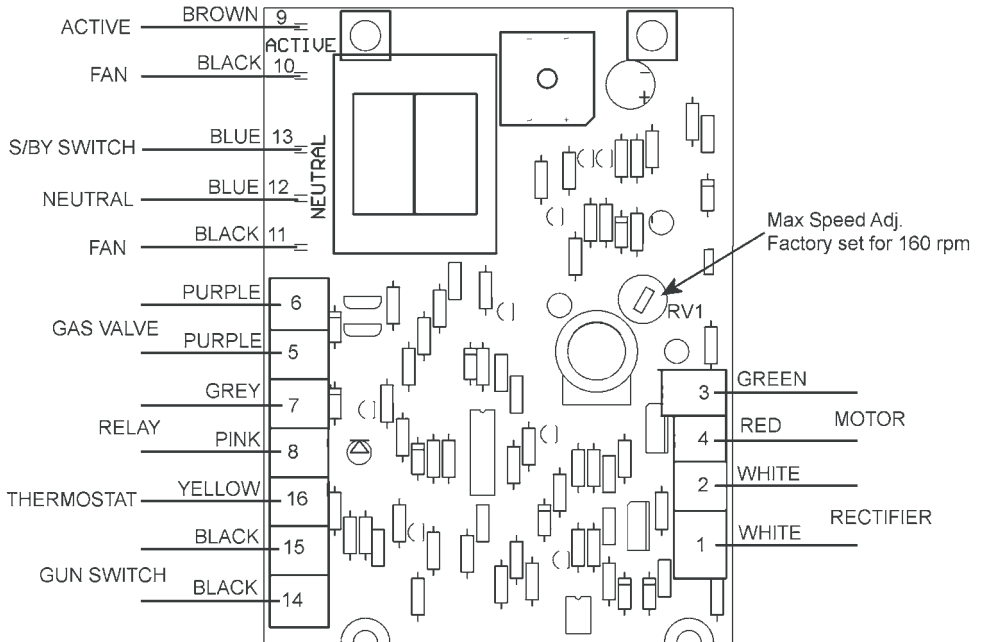
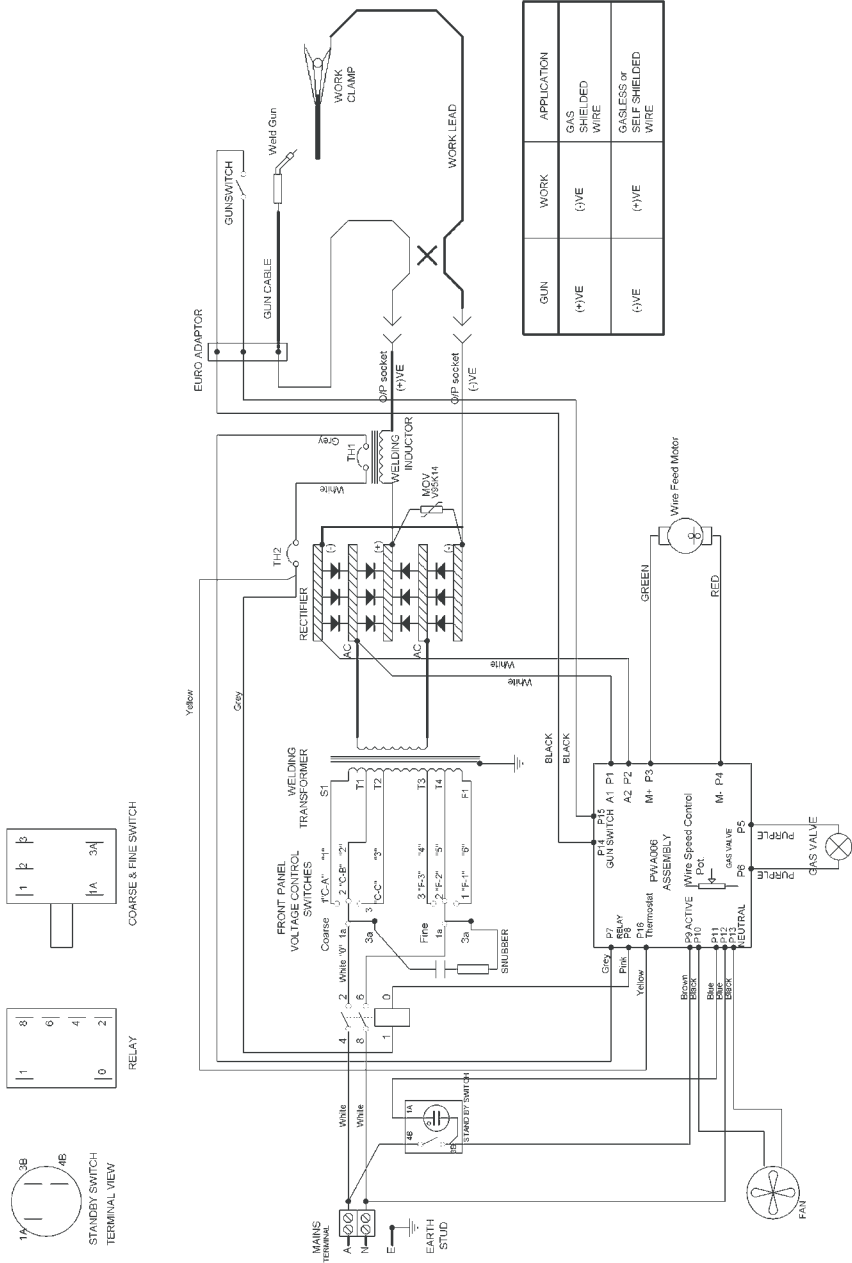

Fig 9 PWA006 Control Board

10.2 Circuit Diagram



Weldmatic 175 / 150
 CP122-0/C1 D

Fig 10 Weldmatic 175 Circuit Diagram

11.1 Assembly and Parts List - Weldmatic 175 Power Source

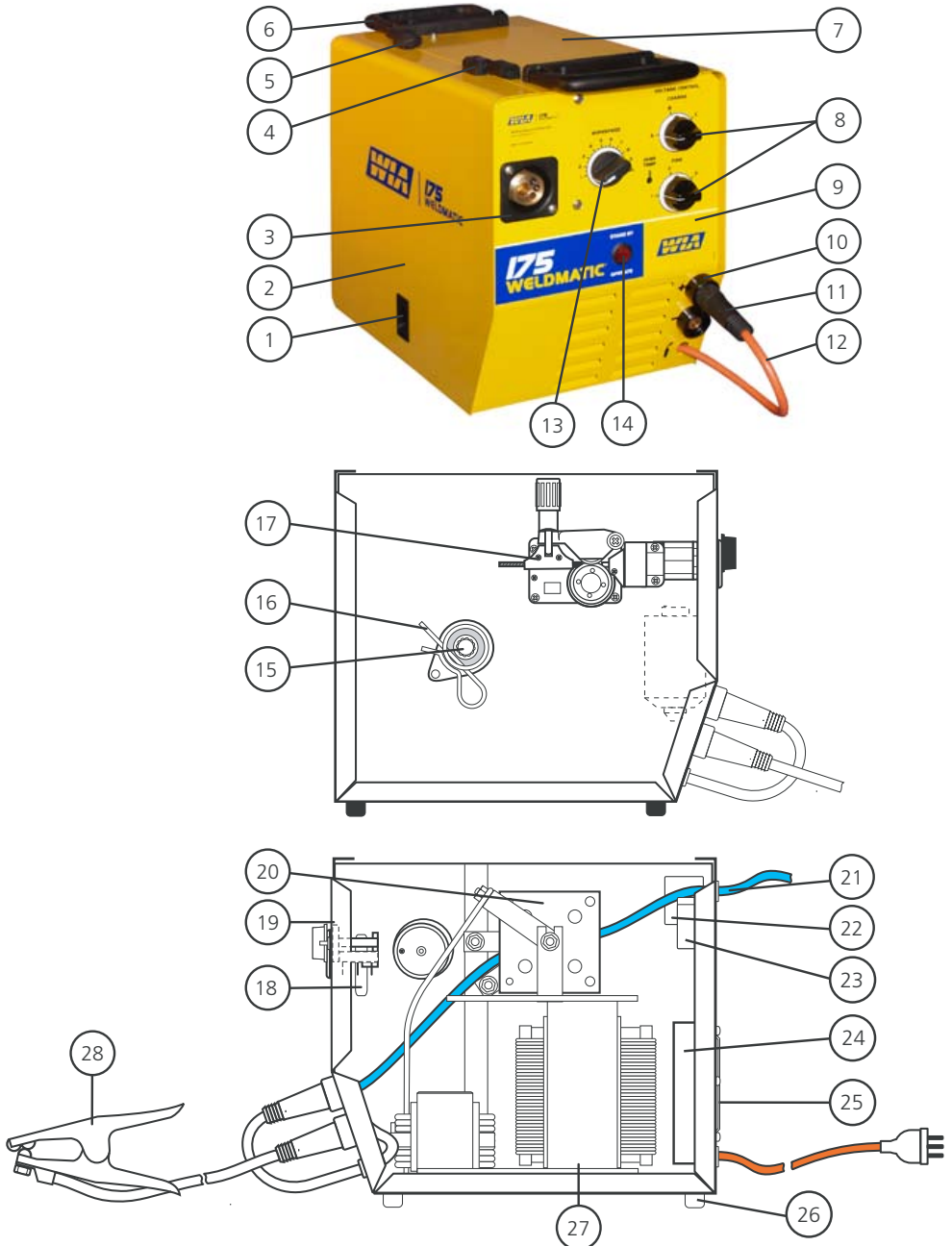

Fig 11 Weldmatic 175 Power Source Assembly

Item #	Part #	Description	Qty
1	W29-1/20	Slam Action Catch	1
2	PAN072	Side Door	1
3	WF001-6	Euro Surround, Plastic	1
4	W41-0/1	Hinge Set Left Hand	1
5	W41-0/2	Hinge Set Right Hand	1
6	MZ208015	Handle Assembly	2
7	PAN073	Side/Top Cover	1
8	CP110-10/1N	Rotary Switch (including knob and dust cover)	2
9	LST022	Label Set Complete	1
10	SA140-0/2	Socket, Dinse	2
11	WGEC3	Plug, Dinse	2
12	CABW10	Welding Cable 10mm ²	1
13	M0029	Adjusting Knob, Large	1
14	E0042	On/Off Switch	1
15	AM321	1/5 kg Spool Holder Assembly	1
16	AM133-3	Rclip (included in AM321)	1
17	WF023	Wirefeed Assembly	1
18	SUB021	Snubber	1
19	PWA006N	Wirefeed Control PCB Assembly	1
20	CP104-0/2	Rectifier	1
	CP3-9/8	Thermostat (included in rectifier)	1
21	62513	Blue Oxy Single Gas Hose, 5 metre	1
22	E0041	Gas valve 24 vdc	1
23	E0044	Relay	1
24	FAN006	Fan Assembly	1
25	CP101-0/17	Fan Finger Guard	1
26	HF200-1/15	Plastic Foot	4
27	TFM042N	Welding Transformer/Inductance Assembly, Wired	1
	CP104-16/2	Thermostat (included in transformer)	1
28	WGWC1	Work Clamp	1
Not shown	REG001	Argon Regulator	1
Not shown	GUN001	200A Gun/Cable Assembly, 3 metre, Euro Connect	1
Not shown	CP122-40	Operating Manual	1

11.2 Assembly and Parts List - Wirefeeder

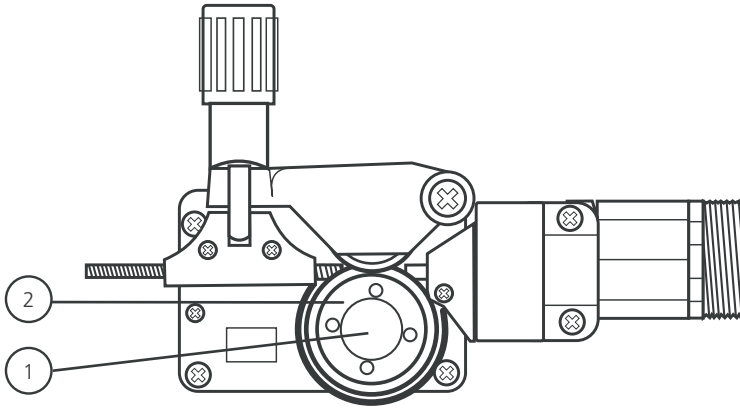

Fig 12 Wirefeed Assembly

Item #	Part #	Description	Qty
1	W27-0/9	Retaining Screw	1

Feed Rolls

Item #	Part #	Description
2	W26-0/8	0.6 + 0.8mm, Solid Wire
2	W26-8/8	0.8 + 0.9mm, Solid Wire
2	W26-7/8	1.0//1.2mm, Flux Cored Wire (knurled)
2	W26-9/8	0.9//1.2mm, Flux Cored Wire (knurled)
2	W25-3/8	1.0/1.2mm, Aluminium

11.3 Assembly and Parts List - Gun and Cable Assembly

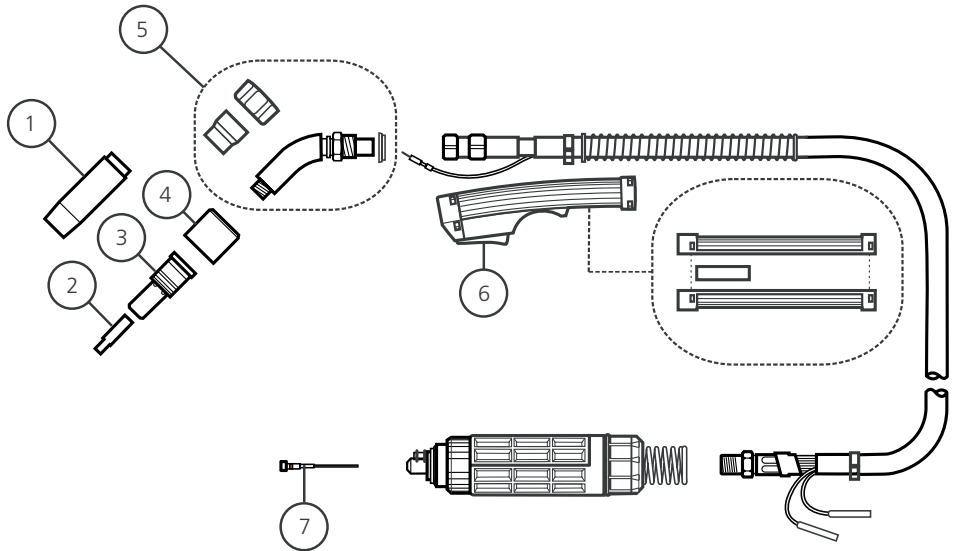

Fig 13 GUN001 (200 amp) Gun and Cable Assembly

Item #	Part #	Description
1	BE4392	Nozzle, Brass, Tapered
2	see 'Tips' page 24	Contact Tip
3	BE4335	Gas Diffuser (Head)
4	BE4323	Cap
5	BEQT2-45 BEQT2-30	Body Tube, 2", 45° (supplied) Body Tube, 2", 30°
6	GUN002	Handle Kit (includes both halves, screws & trigger)
7	BE43115 BE43115X	Steel Liner 0.9 - 1.2mm Nylon Liner 0.9 - 1.2mm

Tips

Wire diameter	Short series (25mm)
0.6mm	BE7497
0.8mm	BE7488
0.9mm	BE7489
1.0mm	BE7496
1.2mm	BE7490

To replace liner: Disconnect gun/cable assembly at the Euro adaptor. Remove nozzle (1) and head (3). Withdraw old liner from the wirefeeder end. Insert new liner and refit gun/cable assembly to the wirefeeder.

At the gun end, compress the liner within the gun cable, then cut it **one contact tip length past the end of the body tube** (5). Refit head, tip and nozzle.

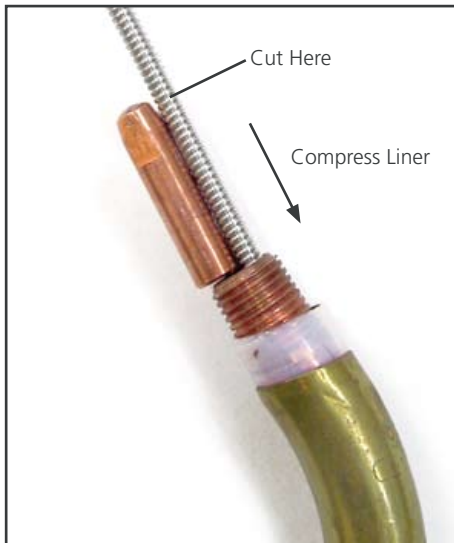

Fig 6 Replacing the gun cable liner

12 Warranty Information



WIA Gold Shield 3 Year Warranty

Effective 1st March 2005

At WIA, we are serious about product quality.

Every new Weldmatic and Weldarc machine comes fully backed by the WIA 'Gold Shield 3 Year Warranty', covering parts and workmanship, so you can be guaranteed you're buying reliability and performance.

This limited warranty supersedes all previous WIA (Welding Industries of Australia) warranties and is exclusive with no other guarantees or warranties expressed or implied.

Limited Warranty

Subject to the terms and conditions below, WIA warrants to its original retail purchaser that new WIA equipment sold after the effective date of this limited warranty is free of defects in material and workmanship at the time it is shipped by WIA.

THIS WARRANTY IS EXPRESSLY IN LIEU OF ALL OTHER WARRANTIES, EXPRESS OR IMPLIED, INCLUDING THE WARRANTIES OF MERCHANTABILITY AND FITNESS.

Within the warranty periods listed below, WIA will repair or replace any warranted parts or components that fail due to such defects in material or workmanship. WIA must be notified in writing within thirty (30) days of such defect or failure, at which time WIA will provide instructions on the warranty claim procedures to be followed.

WIA shall honour warranty claims on warranted equipment in the event of such a failure within the warranty time periods. All warranty time periods start on the date that the equipment was delivered to the original retail purchaser, or 18 months after the equipment date of manufacture, whichever is the earlier.

Parts and workmanship on Weldarc and Weldmatic equipment are covered for a period of 3 years (except for gas regulator, gun cable and consumables listed below.)

Items replaced under original warranty are warranted for the remainder of the original equipment warranty, or for a period of ninety (90) days, whichever is the greater.

Gas regulator and gun/cable assembly are warranted for 90 days.

WIA's Limited Warranty shall not apply to:

- 1 Consumable components; such as contact tips, cutting nozzles, contactors, brushes, relays or parts that fail due to normal wear.
- 2 Equipment that has been modified by any party other than WIA, or equipment that has been improperly installed, improperly operated or misused based upon industry standards, or equipment which has not had reasonable and necessary maintenance, or equipment which has been used for operation outside of the specifications for the equipment.

WIA PRODUCTS ARE INTENDED FOR PURCHASE AND USE BY COMMERCIAL / INDUSTRIAL USERS AND PERSONS TRAINED AND EXPERIENCED IN THE USE AND MAINTENANCE OF WELDING EQUIPMENT.

In the event of a warranty claim covered by this warranty, the exclusive remedies shall be, at WIA's option: (1) repair; or

(2) replacement; or, where authorised in writing by WIA in appropriate cases, (3) the reasonable cost of repair or replacement by an authorised WIA service agent; or (4) payment of or credit for the purchase price (less reasonable depreciation based upon actual use) upon return of the goods at customer's risk and expense.

WIA's option of repair or replacement will be F. O. B. Factory at Melrose Park, Adelaide, or F. O. B. at a WIA authorised service facility as determined by WIA. Therefore no compensation or reimbursement for transportation costs of any kind will be allowed.

TO THE EXTENT PERMITTED BY LAW, THE REMEDIES PROVIDED HEREIN ARE THE SOLE AND EXCLUSIVE REMEDIES. IN NO EVENT SHALL WIA BE LIABLE FOR DIRECT, INDIRECT, SPECIAL, INCIDENTAL OR CONSEQUENTIAL DAMAGES (INCLUDING LOSS OF PROFIT), WHETHER BASED ON CONTRACT, TORT OR ANY OTHER LEGAL THEORY.

ANY EXPRESS WARRANTY NOT PROVIDED HEREIN AND ANY IMPLIED WARRANTY, GUARANTEE OR REPRESENTATION AS TO PERFORMANCE, AND ANY REMEDY FOR BREACH OF CONTRACT TORT OR ANY OTHER

LEGAL THEORY WHICH, BUT FOR THIS PROVISION, MIGHT ARISE BY IMPLICATION, OPERATION OF LAW, CUSTOM OF TRADE OR COURSE OF DEALING, INCLUDING ANY IMPLIED WARRANTY OF MERCHANTABILITY OR FITNESS FOR PARTICULAR PURPOSE, WITH RESPECT TO ANY AND ALL EQUIPMENT FURNISHED BY WIA IS EXCLUDED AND DISCLAIMED BY WIA.