



OM-256 016A

2012-03

ITW

Auto-Darkening Helmets Model: Titanium™ Series w/Infotrack™

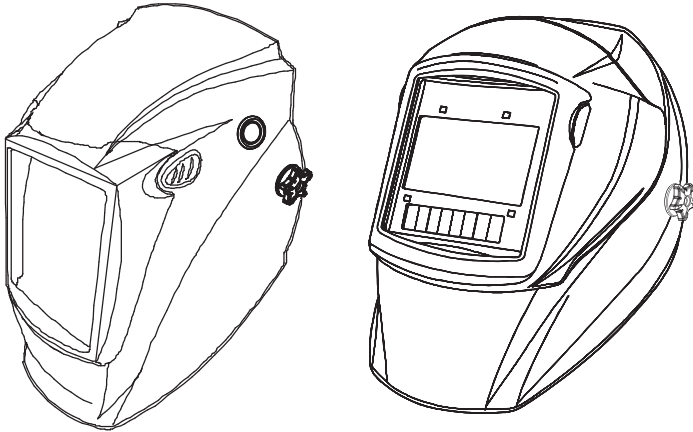

To help us serve you better, go to www.MillerWelds.Com/Register

TABLE OF CONTENTS

SECTION 1 – WELDING HELMET SAFETY PRECAUTIONS –READ BEFORE USING	1
1-1. Symbol Usage	1
1-2. Arc Welding Hazards	1
1-3. Proposition 65 Warnings	2
1-4. Lens Shade Selection Table	3
1-5. Principal Safety Standards	3
SECTION 2 – SPECIFICATIONS	4
SECTION 3 – OPERATING INSTRUCTIONS – TITANIUM 7300/9400 HELMETS	5
3-1. Helmet Configurations (Titanium 7300 And 9400 Series Helmets)	5
3-2. Helmet Controls (Titanium 7300 And 9400 Series Helmets)	6
3-3. Auto On/Off Button And Grind Mode / Low Battery Light (Titanium 7300 And 9400 Series Helmets)	7
3-4. Mode Control Button (Titanium 7300 And 9400 Series Helmets)	8
3-5. Variable Shade Control (Titanium 7300 And 9400 Series Helmets)	9
3-6. Lens Delay Control (Titanium 7300 And 9400 Series Helmets)	10
3-7. Sensitivity Control (Titanium 7300 And 9400 Series Helmets)	11
3-8. Typical Lens Adjustment Procedure	12
3-9. Info Control Button (Titanium 7300 And 9400 Series Helmets)	13
3-10. Arc Time Control (Titanium 7300 And 9400 Series Helmets)	14
3-11. Clock Control (Titanium 7300 And 9400 Series Helmets)	15
3-12. Temp. Control (Titanium 7300 And 9400 Series Helmets)	16
3-13. Alarm Control (Titanium 7300 And 9400 Series Helmets)	17
SECTION 4 – OPERATING INSTRUCTIONS – TITANIUM 1600/1600i HELMETS	18
4-1. Controls – Titanium 1600 And 1600i Series Helmets	18
SECTION 5 – ADJUSTING HEADGEAR	19
5-1. Adjusting Headgear On Titanium 7300 And 9400 Series Helmets	19
5-2. Adjusting Headgear On Titanium 1600 And 1600i Series Helmets	20
SECTION 6 – REPLACING THE GRINDING SHIELD OR LENS COVERS	21
6-1. Replacing Grinding Shield On 9400i And 1600i Helmets	21
6-2. Replacing Lens Covers On Quick Release Helmets	22
SECTION 7 – REPLACING THE BATTERY (AUTO-DARKENING LENS ASSEMBLIES)	23
7-1. Replacing The Battery In Titanium 7300 And 9400 Series Helmets	23
SECTION 8 – INSTALLING OPTIONAL MAGNIFYING LENS	24
SECTION 9 – MAINTENANCE	24
SECTION 10 – TROUBLESHOOTING	25
SECTION 11 – PARTS LISTS	26
SECTION 12 – LIMITED WARRANTY	36

SECTION 1 – WELDING HELMET SAFETY PRECAUTIONS – READ BEFORE USING

helmet 2012-02

 **Protect yourself and others from injury — read, follow, and save these important safety precautions and operating instructions.**

1-1. Symbol Usage



DANGER! – Indicates a hazardous situation which, if not avoided, will result in death or serious injury. The possible hazards are shown in the adjoining symbols or explained in the text.

 Indicates special instructions.



Indicates a hazardous situation which, if not avoided, could result in death or serious injury. The possible hazards are shown in the adjoining symbols or explained in the text.

This group of symbols means Warning! Watch Out! ELECTRIC SHOCK, MOVING PARTS, and HOT PARTS hazards. Consult symbols and related instructions below for necessary actions to avoid the hazards.

NOTICE – Indicates statements not related to personal injury.

1-2. Arc Welding Hazards

 **Only qualified persons should install, operate, maintain, and repair this unit.**



ARC RAYS can burn eyes and skin.

Arc rays from the welding process produce intense visible and invisible (ultraviolet and infrared) rays that can burn eyes and skin. Sparks fly off from the weld.

- Wear a welding helmet fitted with a proper shade of filter to protect your face and eyes when welding or watching (see ANSI Z49.1 and Z87.1 listed in Safety Standards). Refer to Lens Shade Selection table in Section 1-4.
- Wear approved safety glasses with side shields under your helmet.
- Use protective screens or barriers to protect others from flash, glare, and sparks; warn others not to watch the arc.
- Wear protective clothing made from durable, flame-resistant material (leather, heavy cotton, and wool) and foot protection.
- Before welding, adjust the auto-darkening lens sensitivity setting to meet the application.
- Stop welding immediately if the auto-darkening lens does not darken when the arc is struck. See the Owner's Manual for more information.



WELDING HELMETS do not provide unlimited eye, ear, and face protection.

Arc rays from the welding process produce intense visible and invisible (ultraviolet and infrared) rays that can burn eyes and skin. Sparks fly off from the weld.

- Use impact resistant safety spectacles or goggles and ear protection at all times when using this welding helmet.
- Do not use this helmet while working with or around explosives or corrosive liquids.
- Do not weld in the overhead position while using this helmet.
- Inspect the auto-lens frequently. Immediately replace any scratched, cracked, or pitted cover lenses or auto-lenses.



NOISE can damage hearing.

Noise from some processes or equipment can damage hearing.

- Wear approved ear protection if noise level is high.

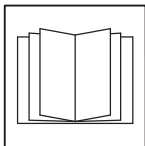

READ INSTRUCTIONS.

- Read and follow all labels and the Owner's Manual carefully before installing, operating, or servicing unit. Read the safety information at the beginning of the manual and in each section.

- Use only genuine replacement parts from the manufacturer.
- Perform maintenance and service according to the Owner's Manuals, industry standards, and national, state, and local codes.



FUMES AND GASES can be hazardous.

Welding produces fumes and gases. Breathing these fumes and gases can be hazardous to your health.

- Keep your head out of the fumes. Do not breathe the fumes.
- If inside, ventilate the area and/or use local forced ventilation at the arc to remove welding fumes and gases.
- If ventilation is poor, wear an approved air-supplied respirator.
- Read and understand the Material Safety Data Sheets (MSDSs) and the manufacturer's instructions for metals, consumables, coatings, cleaners, and degreasers.
- Work in a confined space only if it is well ventilated, or while wearing an air-supplied respirator. Always have a trained watchperson nearby. Welding fumes and gases can displace air and lower the oxygen level causing injury or death. Be sure the breathing air is safe.
- Do not weld in locations near degreasing, cleaning, or spraying operations. The heat and rays of the arc can react with vapors to form highly toxic and irritating gases.
- Do not weld on coated metals, such as galvanized, lead, or cadmium plated steel, unless the coating is removed from the weld area, the area is well ventilated, and while wearing an air-supplied respirator. The coatings and any metals containing these elements can give off toxic fumes if welded.

1-3. Proposition 65 Warnings



Welding or cutting equipment produces fumes or gases which contain chemicals known to the State of California to cause birth defects and, in some cases, cancer. (California Health & Safety Code Section 25249.5 et seq.)



This product contains chemicals, including lead, known to the state of California to cause cancer, birth defects, or other reproductive harm. *Wash hands after use.*

1-4. Lens Shade Selection Table

Process	Electrode Size in. (mm)	Arc Current in Amperes	Minimum Protective Shade No.	Suggested Shade No. (Comfort)*
Shielded Metal Arc Welding (SMAW)	Less than 3/32 (2.4) 3/32–5/32 (2.4–4.0) 5/32–1/4 (4.0–6.4) More than 1/4 (6.4)	Less than 60	7	--
		60–160	8	10
		160–250	10	12
		250–550	11	14
Gas Metal Arc Welding (GMAW) Flux Cored Arc Welding (FCAW)		Less than 60	7	--
		60–160	10	11
		160–250	10	12
		250–500	10	14
Gas Tungsten Arc Welding (TIG)		Less than 50	8	10
		50–150	8	12
		150–500	10	14
Air Carbon Arc Cutting (CAC-A)	Light Heavy	Less than 500	10	12
		500–1000	11	14
Plasma Arc Cutting (PAC)		Less than 20	4	4
		20–40	5	5
		40–60	6	6
		60–80	8	8
		80–300	8	9
		300–400	9	12
Plasma Arc Welding (PAW)		Less than 20	6	6–8
		20–100	8	10
		100–400	10	12
		400–800	11	14

Reference: ANSI Z49.1:2005

* Start with a shade that is too dark to see the weld zone. Then, go to a lighter shade which gives a sufficient view of the weld zone without going below the minimum.

1-5. Principal Safety Standards

Safety in Welding, Cutting, and Allied Processes, ANSI Standard Z49.1, is available as a free download from the American Welding Society at <http://www.aws.org> or purchased from Global Engineering Documents (phone: 1-877-413-5184, website: www.global.ihhs.com).

Safe Practice For Occupational And Educational Eye And Face Protection, ANSI Standard Z87.1, from American National Standards Institute, 25 West 43rd Street, New York, NY 10036 (phone: 212-642-4900, website: www.ansi.org).

SECTION 2 – SPECIFICATIONS

Specification	Titanium 7300	Titanium 9400 Titanium 9400i	Titanium 1600 Titanium 1600i
Viewing Field	3.81 x 1.85 in (97 x 47 mm)	3.81 x 2.62 in (97 x 60mm)	3.86 x 3.54 in. (98 x 90 mm)
Reaction Time	0.0000500 sec (1/20,000)		--
Available Shades <i>All Shades Provide Continuous UV And IR Protection.</i>	Weld Mode Darkened State: No. 9 – No. 13 Light State: No. 4 Cut Mode Darkened State: No. 5 – No. 9 Light State: No. 4 Grind Mode Light State: No. 4 X-Mode Darkened State: No. 9 – No. 13 Light State: No. 4		Standard: No. 10 Upgradeable To Auto-Darkening Lens
Sensitivity Control	Adjustable For Varying Ambient Light And Welding Arc		--
Delay Control	Slows Lens Dark-To-Light State Between 0.1 And 1.0 Seconds		--
Automatic Power Off	Shuts Lens Off 45 Minutes After Last Arc Is Struck		--
Low Battery Light	Red Led Illuminates To Indicate 2–3 Days Remaining Battery Life		--
Power Supply	CR2450 Lithium Batteries (Miller Part No. 217 043)		--
Sensors	Independent/Redundant (Three)	Independent/Redundant (Four)	--
Operating Temperature	14°F to 131°F / –10°C to +55°C ☞ <i>When Stored In Extremely Cold Temperatures, Warm Helmet To Ambient Temperature Before Welding.</i>		--
Storage Temperature	–4°F to 158°F / –20°C to +70°C ☞ <i>When Stored In Extremely Cold Temperatures, Warm Helmet To Ambient Temperature Before Welding.</i>		--
Total Weight	21 oz (595 g)	Titanium 9400: 21 oz (595 g) Titanium 9400i: 26 oz (737 g)	Titanium 1600: 17 oz (481.9 g) Titanium 1600i: 22 oz (630 g)
Standards	ANSI Z87.1+(2010) and CE/CSA	ANSI Z87.1+(2010) and CE/DIN/CSA/TUV	ANSI Z87.1+(2010) And CE/DIN/CSA/TUV
Warranty	Three Years From Date Of Purchase (Section 12)		30 Day Limited

SECTION 3 – OPERATING INSTRUCTIONS – TITANIUM 7300 And 9400 SERIES HELMETS

3-1. Helmet Configurations (Titanium 7300 And 9400 Series Helmets)

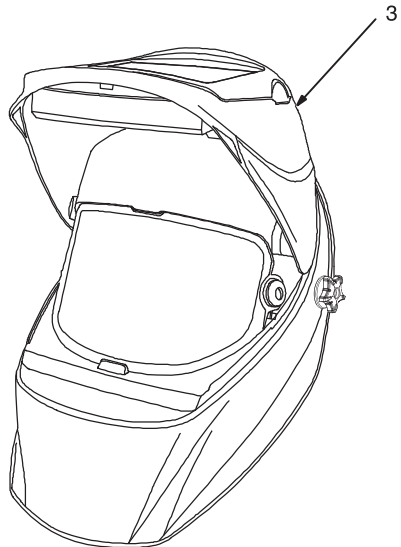
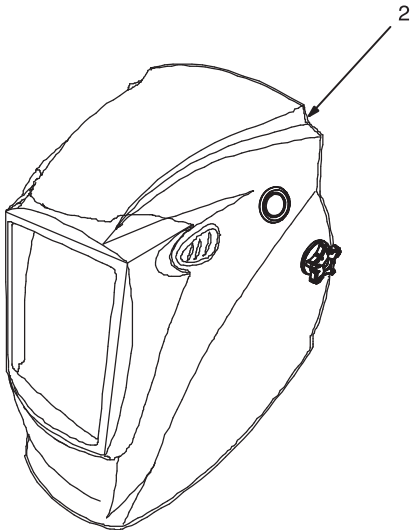
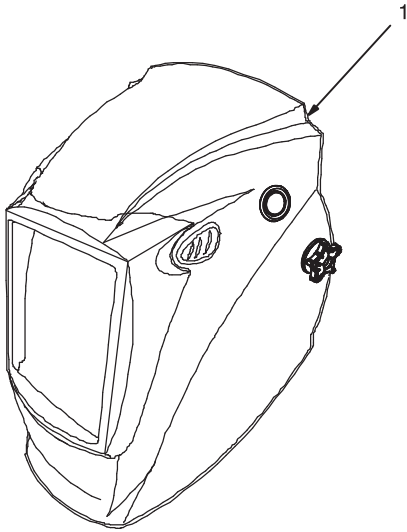

1 Titanium 7300 Helmet

The 7300 helmet features a large fixed-position, auto-darkening lens and is designed for standard welding applications.

2 Titanium 9400 Helmet

The 9400 helmet features a larger fixed position, auto-darkening lens than the 7300 series and is also designed for standard welding applications.

3 Titanium 9400i Helmet

The 9400i helmet features a flip-up auto-darkening lens and a separate, clear grinding shield. Flip the lens up when grinding and performing other non-welding work. Flip the lens down when welding or cutting.

3-2. Helmet Controls (Titanium 7300 And 9400 Series Helmets)

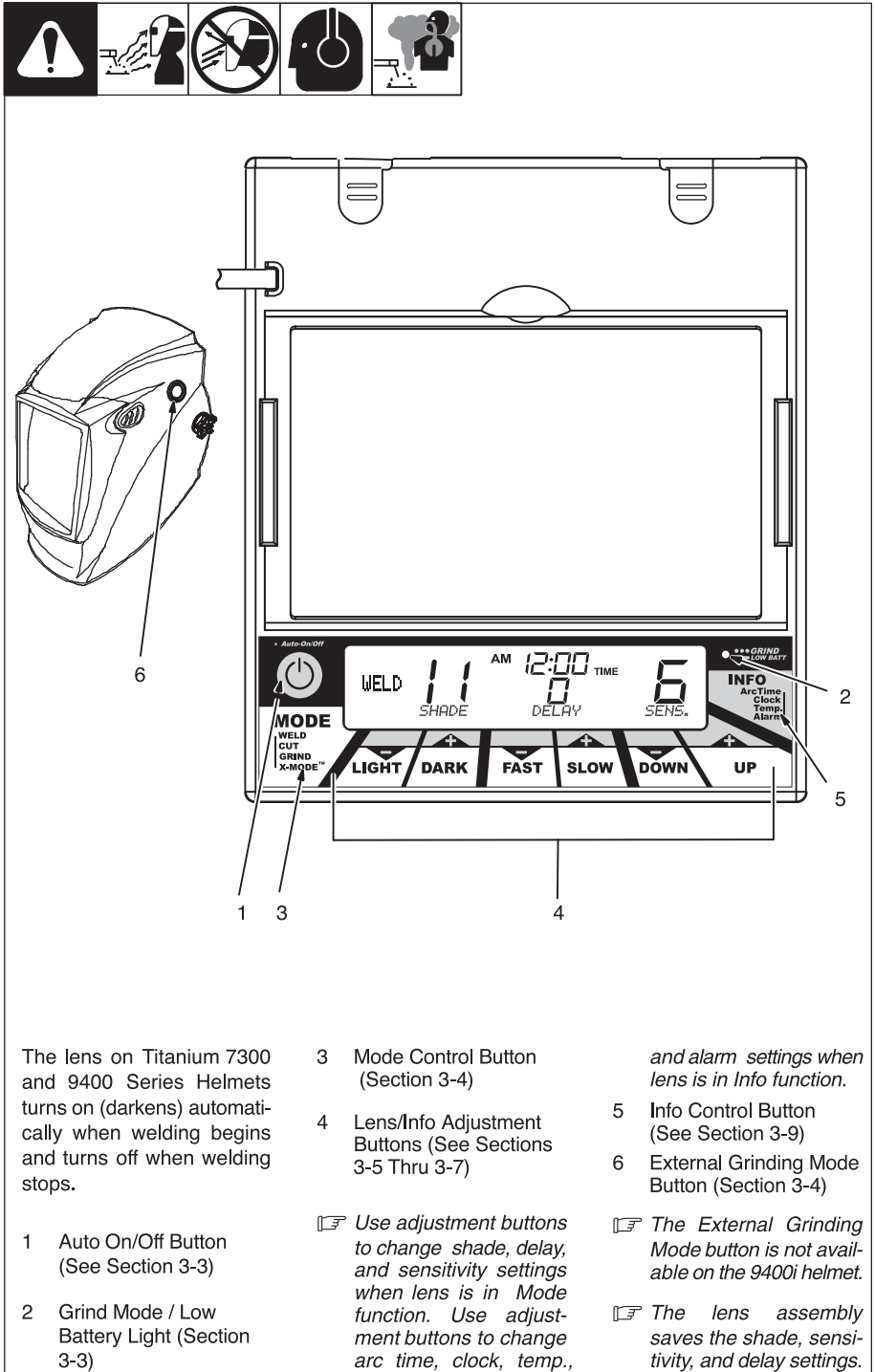

The lens on Titanium 7300 and 9400 Series Helmets turns on (darkens) automatically when welding begins and turns off when welding stops.

- 1 Auto On/Off Button (See Section 3-3)
- 2 Grind Mode / Low Battery Light (Section 3-3)

- 3 Mode Control Button (Section 3-4)
- 4 Lens/Info Adjustment Buttons (See Sections 3-5 Thru 3-7)





☞ Use adjustment buttons to change shade, delay, and sensitivity settings when lens is in Mode function. Use adjustment buttons to change arc time, clock, temp.,

- 5 Info Control Button (See Section 3-9)
- 6 External Grinding Mode Button (Section 3-4)

☞ The External Grinding Mode button is not available on the 9400i helmet.

☞ The lens assembly saves the shade, sensitivity, and delay settings.

3-3. Auto On/Off Button And Grind Mode / Low Battery Light (Titanium 7300 And 9400 Series Helmets)

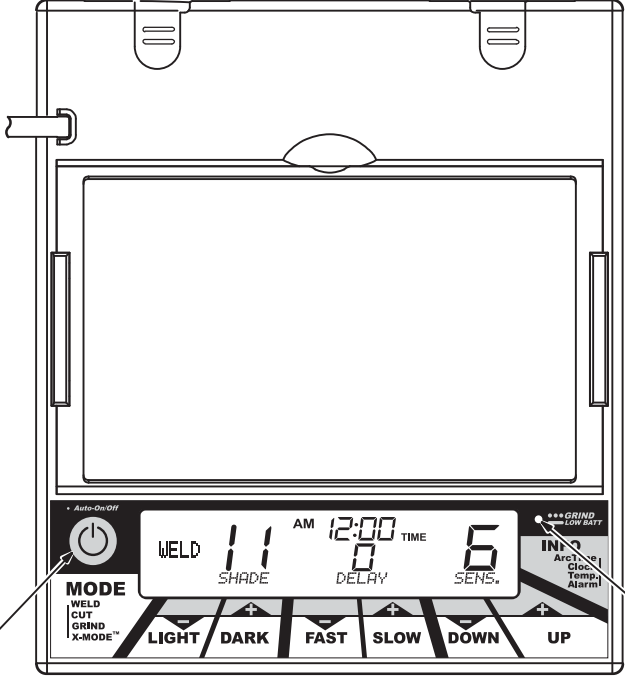

1 Auto On/Off Button

Press Auto On/Off button to check if the lens is working properly and to begin Mode and Info adjustments.

When the On/Off button is pressed, the lens should darken and return to the clear state. Do not use the helmet if the lens does not function as described. (See Section 10, Troubleshooting.)

2 Grind / Low Battery Light

The Grind / Low Battery light blinks when the lens is in the Grind mode. Light stays on when 2–3 days of battery life remain.

If battery power is low, replace with CR2450 lithium batteries (2 required – Miller Part No. 217 043). See Section 7.

3-4. Mode Control Button (Titanium 7300 And 9400 Series Helmets)

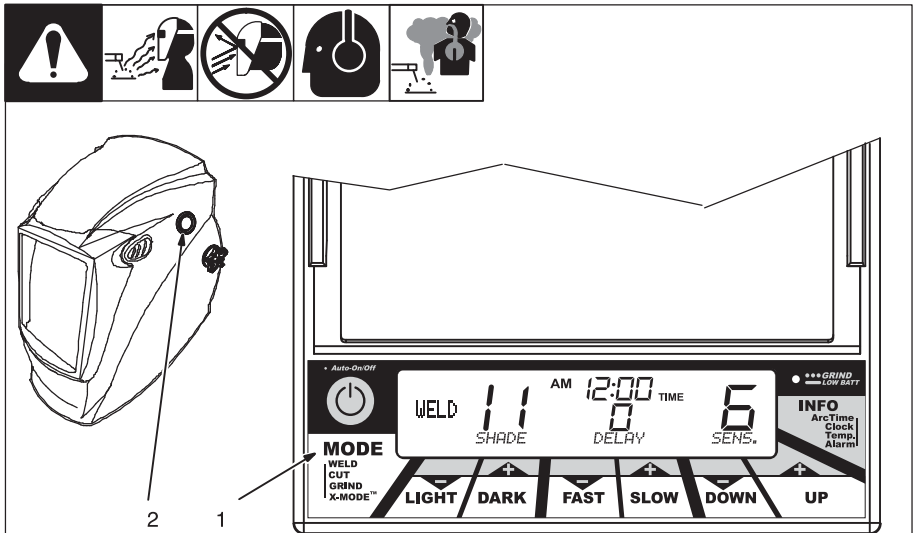

- 1 Mode Control Button
- 2 External Grind Mode Button

Press Mode button to select the mode appropriate for the work activity:

Weld Mode – used for most welding applications. In this mode the lens turns on when it optically senses a welding arc. Adjust shade, sensitivity, and delay settings as needed.

Cut Mode – used for cutting applications. In this mode the lens turns on when it optically senses a cutting arc. Adjust shade, sensitivity, and delay settings as needed.

⚠ If nearby objects may inadvertently contact the external Grind Mode button while you are welding, unplug the Grind Mode button to prevent accidental activation of the Grind mode.

Grind Mode – used for metal grinding applications. In this mode the shade is fixed shade No. 4. No lens adjustments are possible.

Use external Grind Mode button to select grinding





mode without raising helmet.

To use Grind mode, push and hold the external Grind button for two seconds. Push Grind Mode button again to turn off Grind mode.

X Mode – used for outdoor or low current welding applications. In this mode the lens turns on when it senses weld current. Adjust shade, sensitivity, and delay settings as needed.

📖 Nearby welding may affect helmet operation when lens is in X-Mode. Stay at least 12 ft (3.7 m) away from other welding activity.

3-5. Variable Shade Control (Titanium 7300 And 9400 Series Helmets)

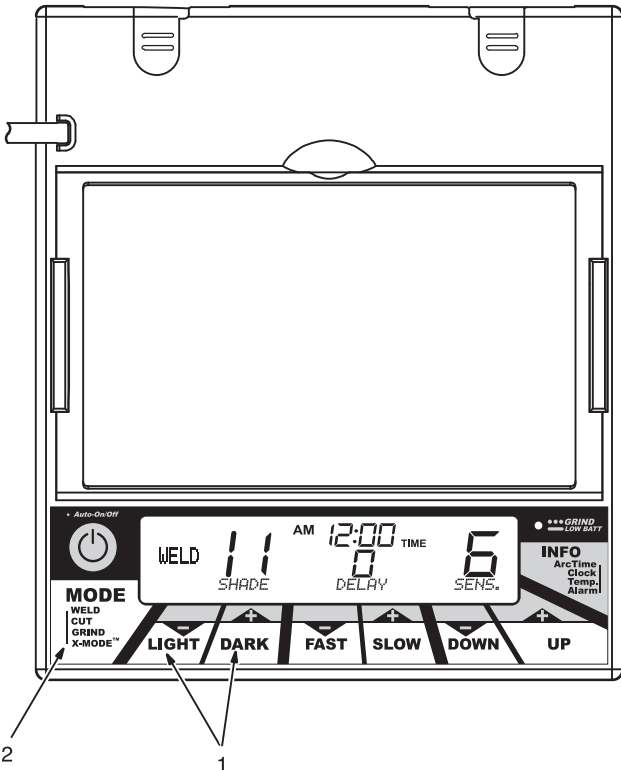

1 Variable Shade Adjustment Buttons

2 Mode Control Button

Use the LIGHT and DARK adjustment buttons to adjust the lens shade in the darkened state. Use the table in Section 1-4 to select proper shade control setting based on your welding process. The shade ranges for each mode are as follows:

Weld – No. 9 – No. 13

Cut – No. 5 – No. 9

Grind – No. 4 only

X Mode – No. 9 – No. 13

Start at the highest setting and adjust lighter to suit the application and your personal preference.

Variable Shade Adjustment Procedure

- Press Auto On/Off button to turn lens On. Helmet lens will darken twice and then clear.
- Press Mode Control Button to select desired function: Weld, Cut, or X-Mode.
- Use LIGHT and DARK adjustment buttons to select desired shade.
- Begin welding or continue with other lens adjustments.

3-6. Lens Delay Control (Titanium 7300 And 9400 Series Helmets)

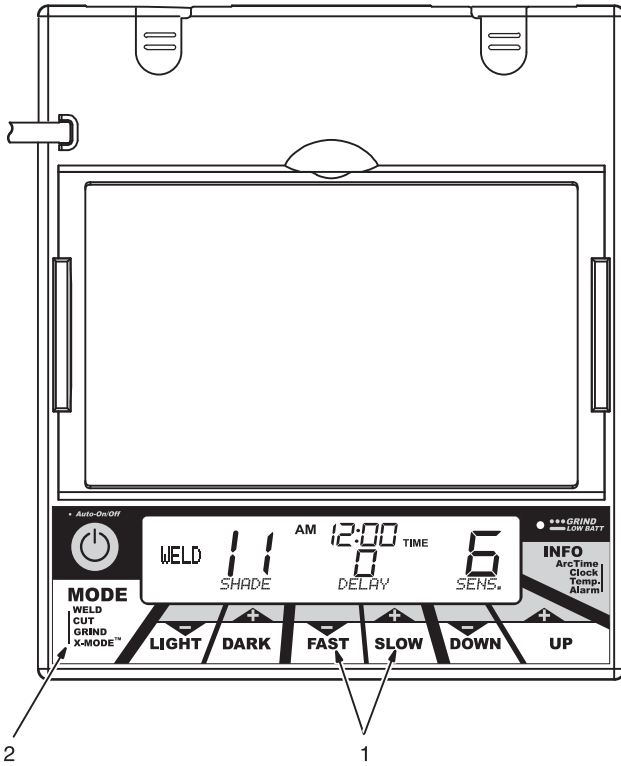

1 Lens Delay Adjustment Buttons

2 Mode Control Button

Use the Lens Delay FAST and SLOW buttons to adjust the time for the lens to switch to the clear state after welding or cutting.

The delay is particularly useful in eliminating bright after-rays present in higher amperage applications where the molten puddle remains bright momentarily after welding. Use the Lens Delay Control buttons to adjust delay from 0 to 10 (0.1 to 1.0 second).

The delay ranges for each mode are as follows:

Weld, Cut, X Modes – 0 – 10

Grind Mode – No delay adjustment

There is no lens delay adjustment in the Grind mode.

Lens Delay Adjustment Procedure

- Press Auto On/Off button to turn helmet On. Helmet lens will darken twice and then clear.
- Press Mode button to select desired function: Weld, Cut, or X-Mode.
- Use FAST and SLOW adjustment buttons to select desired delay.
- Begin welding or continue with other lens adjustments.

3-7. Sensitivity Control (Titanium 7300 And 9400 Series Helmets)

1 Sensitivity Adjustment Buttons

2 Mode Control Button

Use control to make the lens more responsive to different light levels in various welding processes. **Use a Mid-Range or 30–50% sensitivity setting for most applications.**

It may be necessary to adjust helmet sensitivity to accommodate different lighting conditions or if lens is flashing On and Off.

The sensitivity ranges for each mode are as follows:
Weld, Cut, X Modes – 0–10
Grind Mode – No sensitivity adjustment

⚠ Do not weld in the Grind mode; the lens will not darken.

Sensitivity Adjustment Procedure

☞ *Adjust helmet sensitivity in lighting conditions helmet will be used in.*

- Press Auto On/Off button to turn helmet On. Helmet lens will darken twice and then clear.
- Press Mode button to select desired function: Weld, Cut, or X-Mode.
- Use Sensitivity DOWN and UP buttons to adjust sensitivity control to lowest setting.

- Face the helmet in the direction of use, exposing it to the surrounding light conditions.
- Press sensitivity UP button until the lens darkens, then press DOWN button until lens clears. An alternative method is to press and hold the Less button until the lens clears.

Helmet is ready for use. Slight readjustment may be necessary for certain applications or if lens is flashing on and off.

☞ *Reduce Sensitivity setting if lens stays dark longer than Delay setting.*

Recommended Sensitivity Settings	
Stick Electrode	Mid-Range
Short Circuiting (MIG)	Low/Mid-Range
Pulsed & Spray (MIG)	Mid-Range
Gas Tungsten Arc (TIG)	Mid/High-Range
Plasma Arc Cutting/Welding	Low/Mid-Range

3-8. Typical Lens Adjustment Procedure



☞ Lens assembly displays prior settings when turned On. Retained settings are not shown in example.

☞ In the Grind mode the lens is a fixed shade No. 4. No lens adjustments are possible.

Adjusting Lens Assembly:

- Turn lens On. Display screen appears.
- Select mode (Weld, Cut, Grind, X-Mode).
- Select shade by pressing LIGHT and DARK buttons.
- Select Delay by pressing FAST and SLOW buttons.
- Select Sensitivity by pressing DOWN and UP Buttons.
- Begin work.

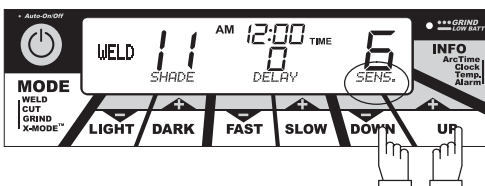
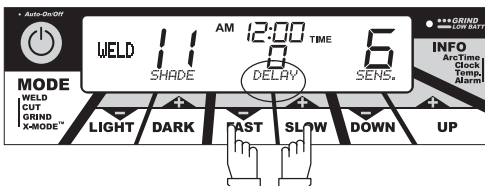
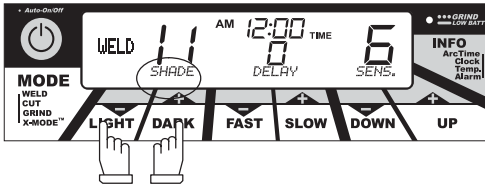
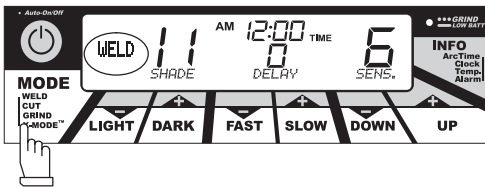
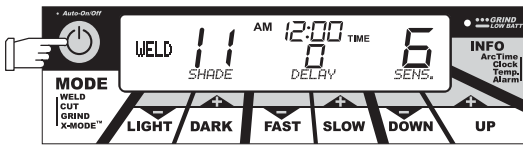

3-9. Info Control Button (Titanium 7300 And 9400 Series Helmets)

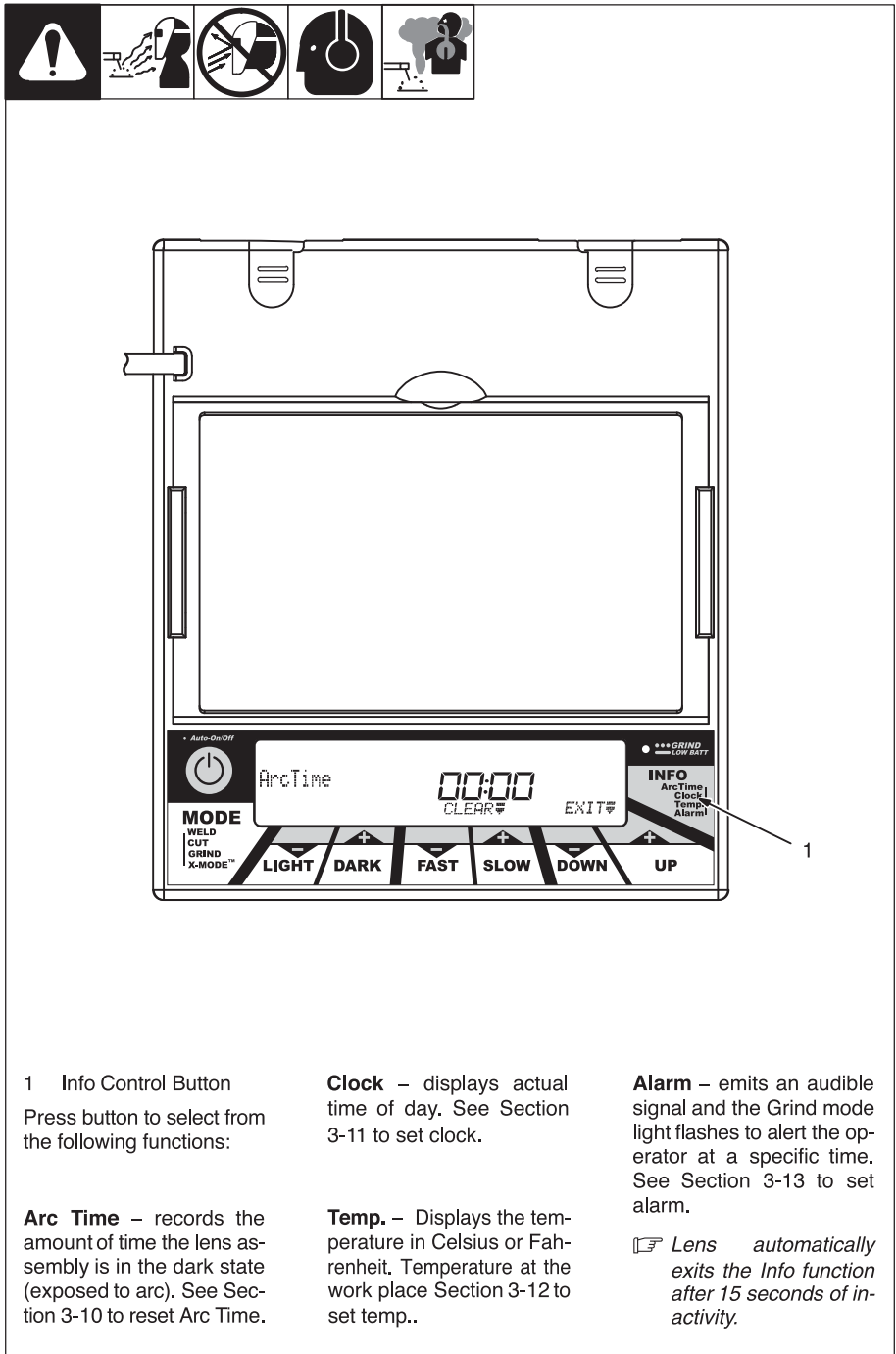

1 Info Control Button
Press button to select from the following functions:

Arc Time – records the amount of time the lens assembly is in the dark state (exposed to arc). See Section 3-10 to reset Arc Time.

Clock – displays actual time of day. See Section 3-11 to set clock.

Temp. – Displays the temperature in Celsius or Fahrenheit. Temperature at the work place Section 3-12 to set temp..

Alarm – emits an audible signal and the Grind mode light flashes to alert the operator at a specific time. See Section 3-13 to set alarm.

⚠ Lens automatically exits the Info function after 15 seconds of inactivity.

3-10. Arc Time Control (Titanium 7300 And 9400 Series Helmets)

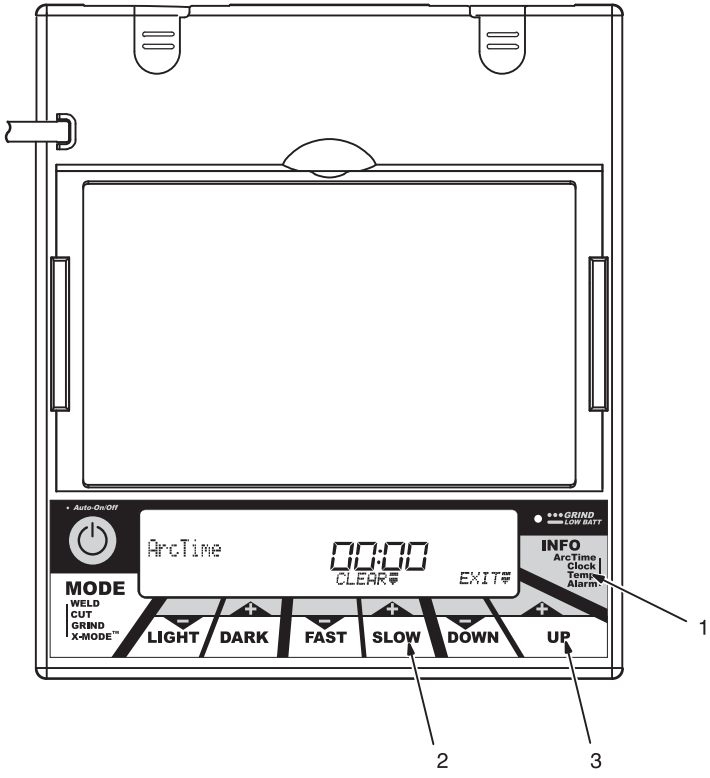

The arc time function records the amount of time the lens assembly is dark (exposed to an arc).

- 1 Info Control Button
- 2 Arc Time Clear Button
- 3 Arc Time Exit Button

Arc Time Procedure

- Press Auto On/Off button to turn helmet On. Helmet lens will darken twice and then clear.
- Press Info button repeatedly until Arc Time is displayed on screen.
- Use the Clear button to reset the arc time to zero.
- Press the Exit button when finished.

3-11. Clock Control (Titanium 7300 And 9400 Series Helmets)

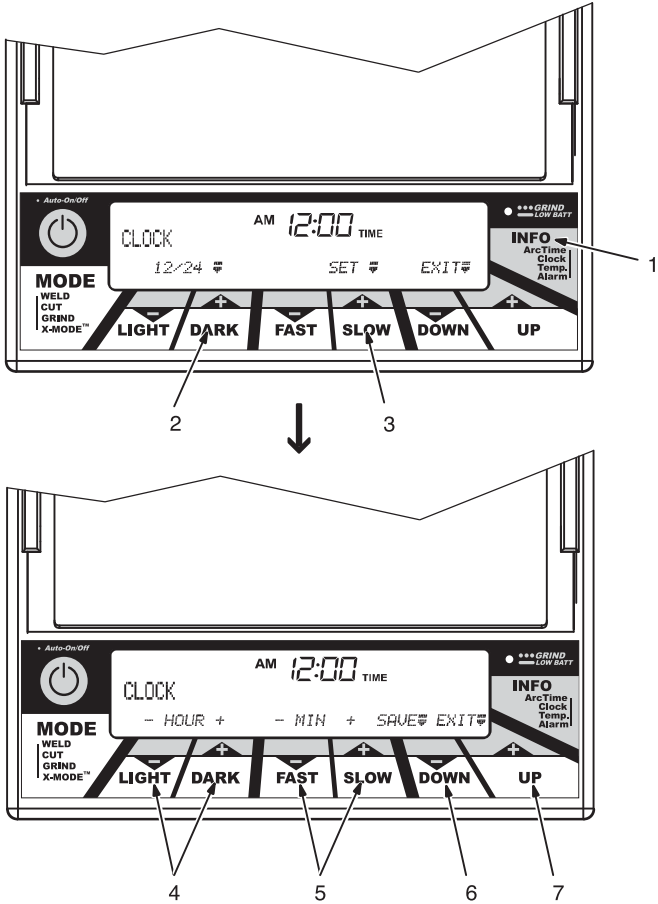

The clock displays the actual time of day.

- 1 Info Control Button
- 2 12/24 Hour Cycle Button
- 3 Clock Set Button
- 4 Hour +/- Buttons
- 5 Minute +/- Buttons
- 6 Save Button
- 7 Exit Button

Clock Procedure

- Press Auto On/Off button to turn helmet On. Helmet lens will darken twice and then clear.
- Press Info button repeatedly until Clock is displayed on screen.
- Press 12/24 button to select either 12 or 24 hour clock format.
- Press the Set button to enter set mode.

- Press Hour +/- buttons to change hour setting.
- Press Minute +/- buttons to change minute setting.
- Press Save button.
- Press the Exit button when finished.

3-12. Temp. Control (Titanium 7300 And 9400 Series Helmets)

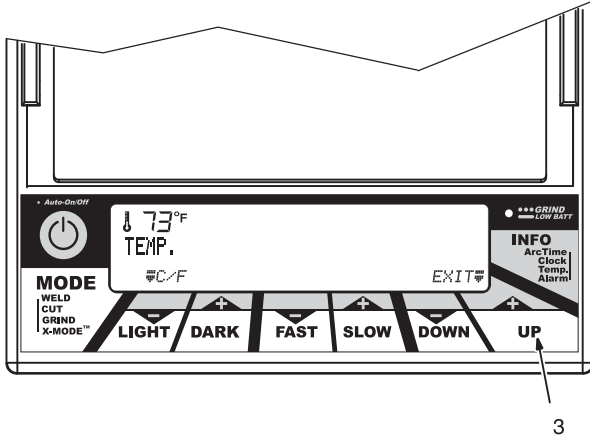
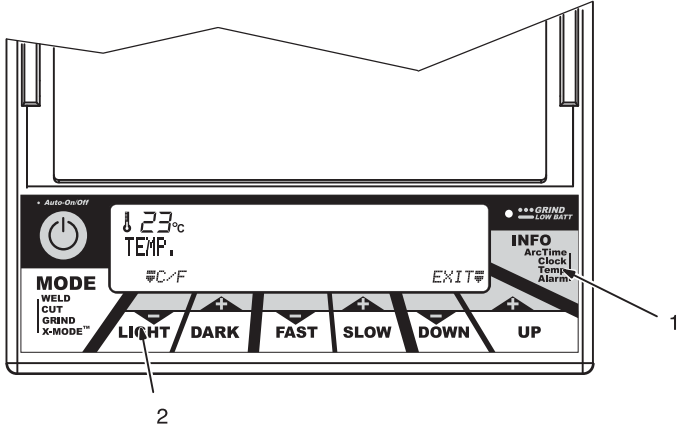

The Temp. displays the current in Celsius or Fahrenheit.

- 1 Info Control Button
- 2 C/F Button
- 3 Exit Button

Temp. Procedure

- Press Auto On/Off button to turn helmet On. Helmet lens will darken twice and then clear.
- Press Info Control button repeatedly until Temp. is displayed on screen.
- Press C/F button to change from Celsius to Fahrenheit.
- Press C/F button to change from Fahrenheit to Celsius.
- Press the Exit button when finished.

3-13. Alarm Control (Titanium 7300 And 9400 Series Helmets)

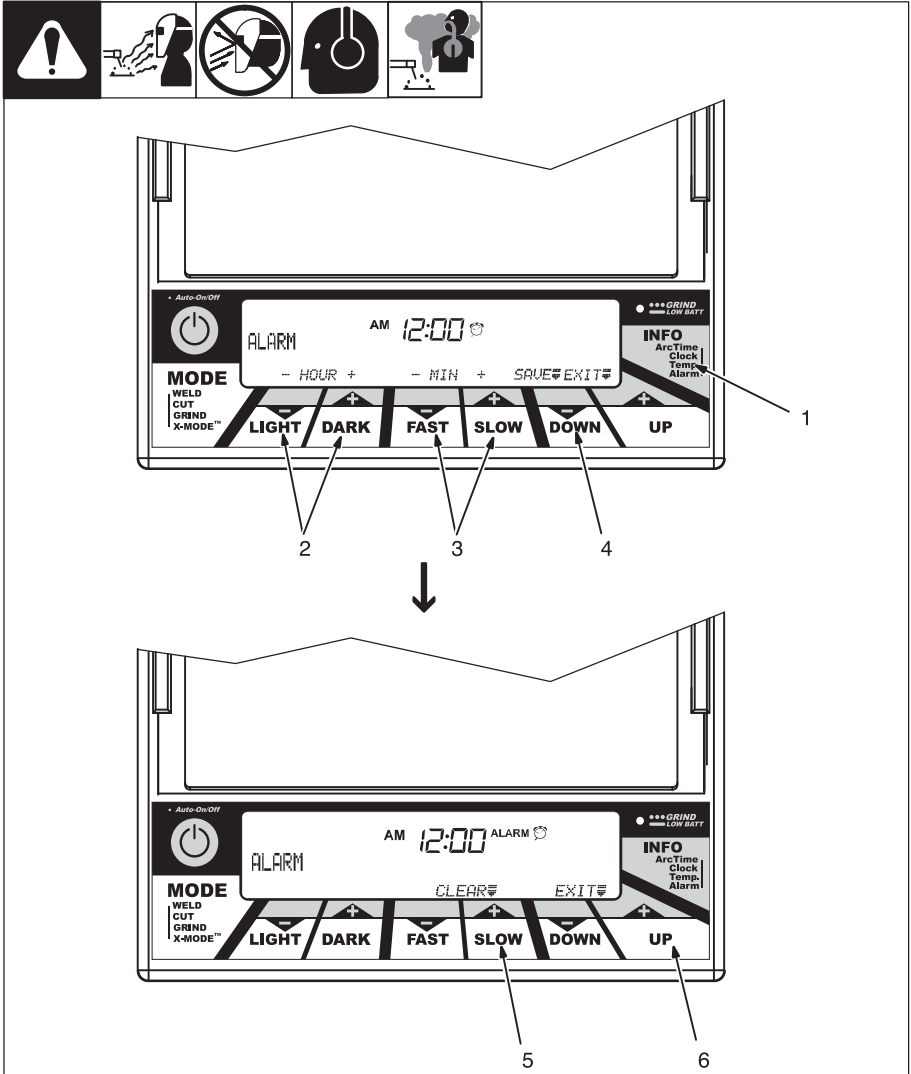

The Alarm emits an audible signal and the Grind mode light flashes to alert the operator at a specific time.

- 1 Info Control Button
- 2 Hour +/- Buttons
- 3 Minute +/- Buttons
- 4 Save Button
- 5 Clear Button
- 6 Exit Button

Alarm Procedure

- Press Auto On/Off button to turn helmet On. Helmet lens will darken twice and then clear.
- Press Info button repeatedly until Alarm is displayed on screen.
- Press Hour +/- buttons to change hour setting.

- Press Minute +/- buttons to change minute setting.
- Press Save button.
- Press the Clear button to start over, or press the Exit button if finished.

Press external Grind Mode button or any lens button to turn off alarm.

SECTION 5 – ADJUSTING HEADGEAR

5-1. Adjusting Headgear On Titanium 7300 And 9400 Series Helmets

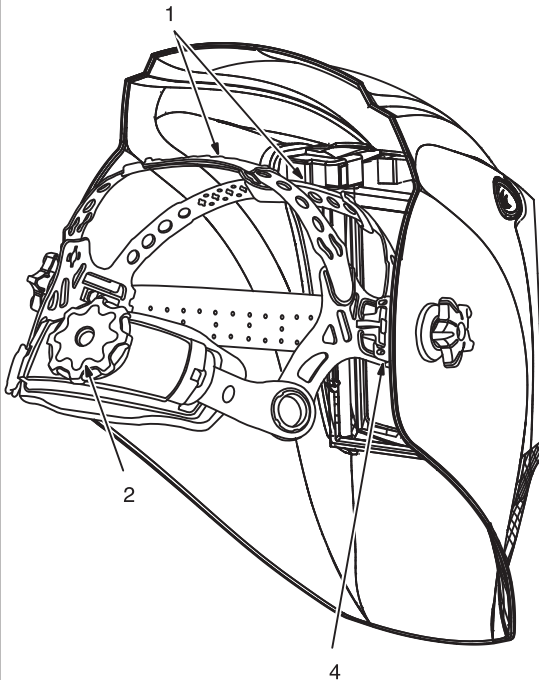

☞ *There are four headgear adjustments: headgear top, tightness, angle adjustment, and distance adjustment.*

1 Headgear Top

Adjusts headgear for proper depth on the head to ensure correct balance and stability.

2 Headgear Tightness

To adjust, turn the adjusting knob located on the back of the headgear left or right to desired tightness.

3 Angle Adjustment (Not Shown)

Seven slots on the right side of the headband provide adjustment for the forward tilt of the helmet. To adjust, lift and reposition the control arm to the desired position.

4 Distance Adjustment

Adjusts the distance between the face and the lens. To adjust, press black tabs on the top and bottom of the pivot point and use other hand to slide headgear forward or backward. Release tabs. (Both sides must be equally positioned for proper vision.)

☞ *Numbers on the adjustment slides indicate set position so both sides can be adjusted equally.*

5-2. Adjusting Headgear On Titanium 1600 And 1600i Series Helmets

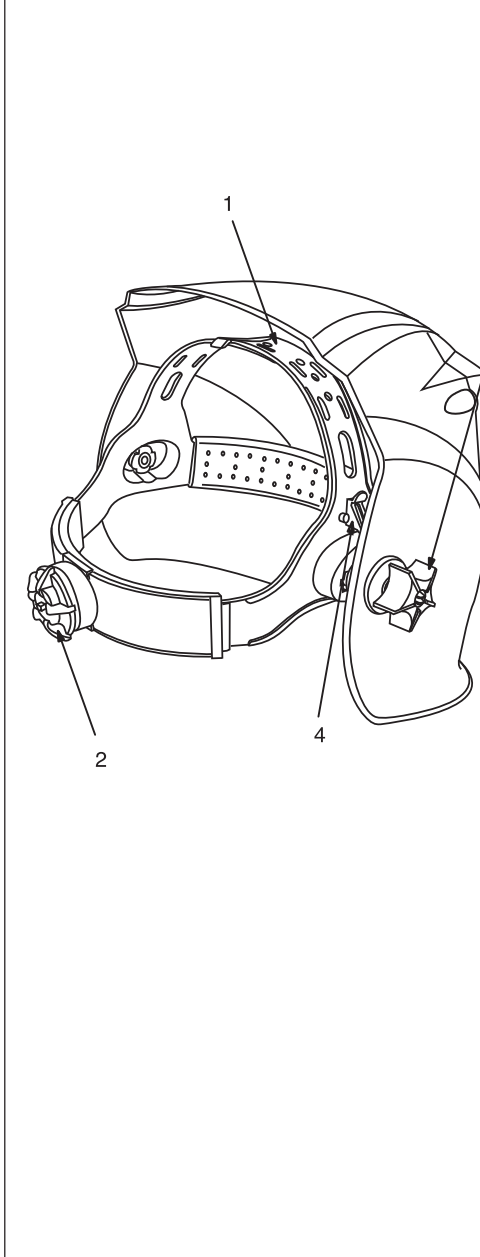

☞ *There are four headgear adjustments: headgear top, tightness, angle adjustment, and distance adjustment.*

1 Headgear Top

Adjusts headgear for proper depth on the head to ensure correct balance and stability.

2 Headgear Tightness

To adjust, push in the adjusting knob located on the back of the headgear and turn left or right to desired tightness.

☞ *If adjustment is limited, it may be necessary to remove the comfort cushion.*

3 Distance Adjustment

Adjusts the distance between the face and the lens. To adjust, loosen both outside tension knobs and press inward to free from adjustment slots. Move forward or back to desired position and retighten. (Both sides must be equally positioned for proper vision.)

4 Angle Adjustment

Four pins on the right side of the headband top provide adjustment for the forward tilt of the helmet. To adjust, loosen the right outside tension adjustment knob then lift on the control arm tab and move it to the desired position. Retighten tension adjustment knob.

☞ *When using the back distance adjustment positions, only the back three angle adjustment pins can be used.*

SECTION 6 – REPLACING THE GRINDING SHIELD OR LENS COVERS

6-1. Replacing Grinding Shield On 9400i And 1600i Helmets

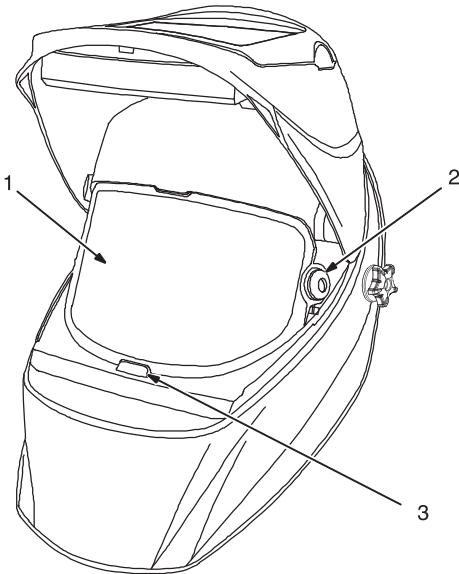

! Never use the auto-darkening lens without the inside and outside lens covers properly installed. Welding spatter will damage the auto-darkening lens and void the warranty.

- 1 Grinding Shield
- 2 Retaining Clip
- 3 Tab

Rotate both retaining clips to the Open position.

Gently push shield toward bottom tab and remove shield from helmet.

Remove retaining clips from shield. Install clips in same location on new shield. (Retaining clips are not interchangeable.)

Install new shield in helmet and rotate clips to the Lock position.

Tear-Away Protective Sheets

Tear-away sheets are available to prolong the life of the grinding shield (see Parts List).

To install tear-away sheets, pull backing from both sides of the tear-away, remove white adhesive backing strips, and place on clear shield.

6-2. Replacing Lens Covers On Quick Release Helmets



⚠ Never use the auto-darkening lens without the inside and outside lens covers properly installed. Welding spatter will damage the auto-darkening lens and void the warranty.

Outside Lens Cover

- 1 Lens Holder
- 2 Release Points
- 3 Outside Lens Cover

Remove lens holder by pressing release points and pulling the holder away from the helmet.

Remove lens cover from holder. Replace lens cover in lens holder. Reinstall lens holder in helmet.

Inside Lens Cover

- 4 Gasket
- 5 Lens
- 6 Inside Lens Cover

Remove the inside lens cover by prying cover from groove in gasket.

Replace the lens cover by gently bowing it in the center and inserting it, one end at a time, into the gasket.

☞ Be sure the cover lens is seated properly (flat) to prevent fogging.

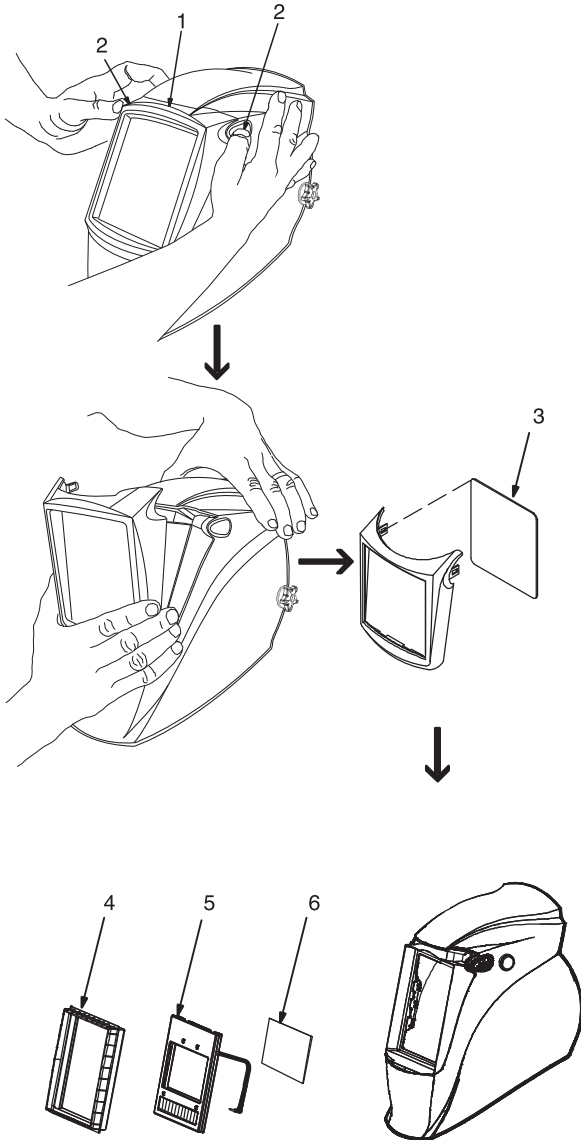

SECTION 7 – REPLACING THE BATTERY (AUTO-DARKENING LENS ASSEMBLIES)

7-1. Replacing The Battery In Titanium 7300 And 9400 Series Helmets

To replace the batteries, remove the auto-darkening lens assembly (see Section 6).

1 Battery Tray

After removing the lens assembly, slide the battery holding trays out and remove the old batteries.

Replace with CR2450 lithium type batteries (2 required) or equivalent (Miller Part No. 217043).

☞ Be sure Positive (+) side of the battery faces up (toward inside of helmet).

Reinstall the battery trays. To test battery, press the Auto On/Off button. The display screen should turn on. Reinstall the lens assembly.

☞ Left and right battery trays are not interchangeable. The auto-darkening helmet will not work if battery trays are installed on the wrong sides.

SECTION 8 – INSTALLING OPTIONAL MAGNIFYING LENS



1 Optional Magnifying Lens

Starting at the bottom, slide magnifying lens into the helmet retaining brackets. Align the magnifying lens with the auto-darkening lens assembly.

- Remove lens holding frame (with auto-darkening lens) from helmet shell.
- Remove auto-darkening lens from lens holder.
- Position lens holder so the magnifying lens holding tabs are facing toward you. From the bottom up, slide magnifying lens into position. (Slide magnifying lens up or down slightly as desired.)
- Reinstall the auto-darkening lens in the lens holder.
- Reverse procedure to remove magnifying lens.

 To prevent lens fogging, install flat side of magnifying lens toward auto-darkening lens.

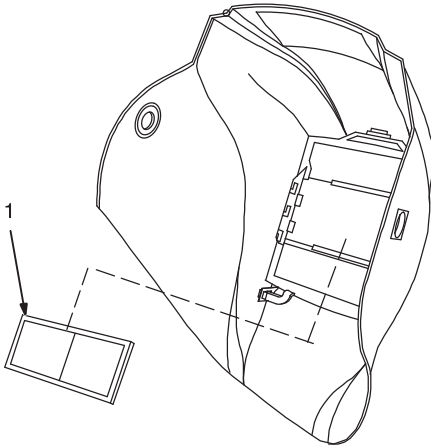

804 818

SECTION 9 – MAINTENANCE

NOTICE – Never use solvents or abrasive cleaning detergents.

NOTICE – Do not immerse the lens assembly in water.

The helmet requires little maintenance. However, for best performance clean after each use. Using a soft cloth dampened with a mild soap and water solution, wipe the cover lenses clean. Allow to air dry. Occasionally, the filter lens and sensors should be cleaned by gently wiping with a soft, dry cloth.

SECTION 10 – TROUBLESHOOTING



Trouble	Remedy
Auto lens not On – auto-lens will not darken momentarily when the Reset button is pressed.	<p>Check batteries and verify they are in good condition and installed properly.</p> <p>Check battery surfaces and contacts and clean if necessary.</p> <p>Check battery for proper contact and gently adjust contact points if necessary. This is particularly important if the helmet has been dropped. Verify left and right battery trays are installed on the correct sides.</p>
Not switching – auto-lens stays light and will not darken when welding.	<p>Stop welding immediately: Press the Auto On/Off button if lens is Auto-On type.</p> <p>If power is On, review the sensitivity recommendations and adjust sensitivity.</p> <p>Clean lens cover and sensors of any obstructions. Make sure the sensors are facing the arc; angles of 45° or more may not allow the arc light to reach the sensors.</p>
Not Switching – auto-lens stays dark after the weld arc is extinguished, or the auto-lens stays dark when no arc is present.	<p>Fine-tune the sensitivity setting in small increments. In extreme light conditions, it may be necessary to reduce the surrounding light levels.</p>
Sections of the auto-lens are not going dark, distinct lines separate the light and dark areas.	<p>Stop welding immediately: The auto-lens may be cracked which can be caused by the impact of dropping the helmet.</p> <p>Weld spatter on the auto lens may also cause cracking. (The lens may need to be replaced; most cracked lenses are not covered by warranty).</p>
Switching or Flickering – the auto-lens darkens then lightens while the welding arc is present.	<p>Review the sensitivity setting recommendations and increase the sensitivity if possible. Be sure the arc sensors are not being blocked from direct access to the arc light.</p> <p>Check the lens cover for dirt and spatter that may be blocking the arc sensors. Increasing Lens Delay 0.1 – 0.3 second may also reduce switching.</p>
Inconsistent or lighter auto-lens shading in the dark-state, noticeable on the outside edges and corners.	<p>Referred to as an angle of view effect, auto-darkening lenses have an optimum viewing angle.</p> <p>The optimum viewing angle is perpendicular or 90° to the surface of the auto-lens. When that angle of view varies in the dark-state, welders may notice slightly lighter areas at the outside edges and the corners of the lens. This is normal and does not represent any health or safety hazard.</p> <p>This effect may also be more noticeable in applications where magnifying lenses are used.</p>

SECTION 11 – PARTS LISTS

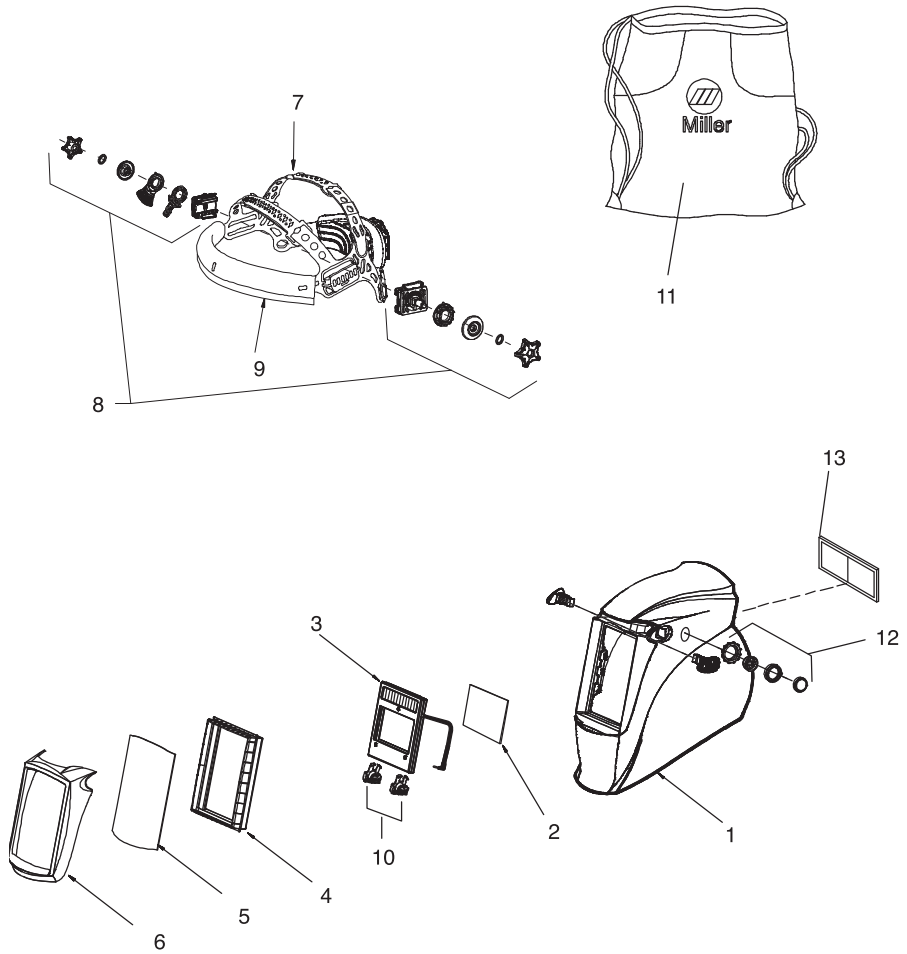

Figure 11-1. Titanium 7300 Auto-Darkening Welding Helmet

Item No.	Part No.	Description	Quantity
----------	----------	-------------	----------

Figure 11-1. Titanium 7300 Auto-Darkening Welding Helmet

1	243 530	Shell, Helmet Titanium (Qr) (Includes Item 6)	1
2	770 237	Lens Cover, Inside 4-1/4in X 2in	1
3	256 358	Lens Assembly, Auto-Darkening Titanium w/Cable	1
4	241 977	Gasket, Lens Assembly	1
5	216 326	Lens Cover, Front 4-11/16in X 5-5/8 in	1
6	243 396	Lens Holder, Titanium (Qr)	1
7	256 174	Headgear, Gray (Includes Items 8 And 9)	1
8	*256 178	Kit, Adjustment Angle/Stop Hardware	1
9	770 249	Headband, Fabric	1
	079 975	Replacement O-Rings (5 Per Pkg.)	1
10	216 339	Tray, Battery (Left/Right)	1
	217 043	Battery, Lithium (CR2450)	2
11	770 250	Bag, Helmet (Miller Logo)	1
	♦222 003	Adapters, Hard Hat (Not Shown)	1
12	256 179	Button, Grind Mode	1
13	♦212 235	Lens, 0.75 Magnification	1
13	♦212 236	Lens, 1.00 Magnification	1
13	♦212 237	Lens, 1.25 Magnification	1
13	♦212 238	Lens, 1.50 Magnification	1
13	♦212 239	Lens, 1.75 Magnification	1
13	♦212 240	Lens, 2.00 Magnification	1
13	♦212 241	Lens, 2.25 Magnification	1
13	♦212 242	Lens, 2.50 Magnification	1

* Adjustment Hardware Kit With O-rings.

♦ Optional

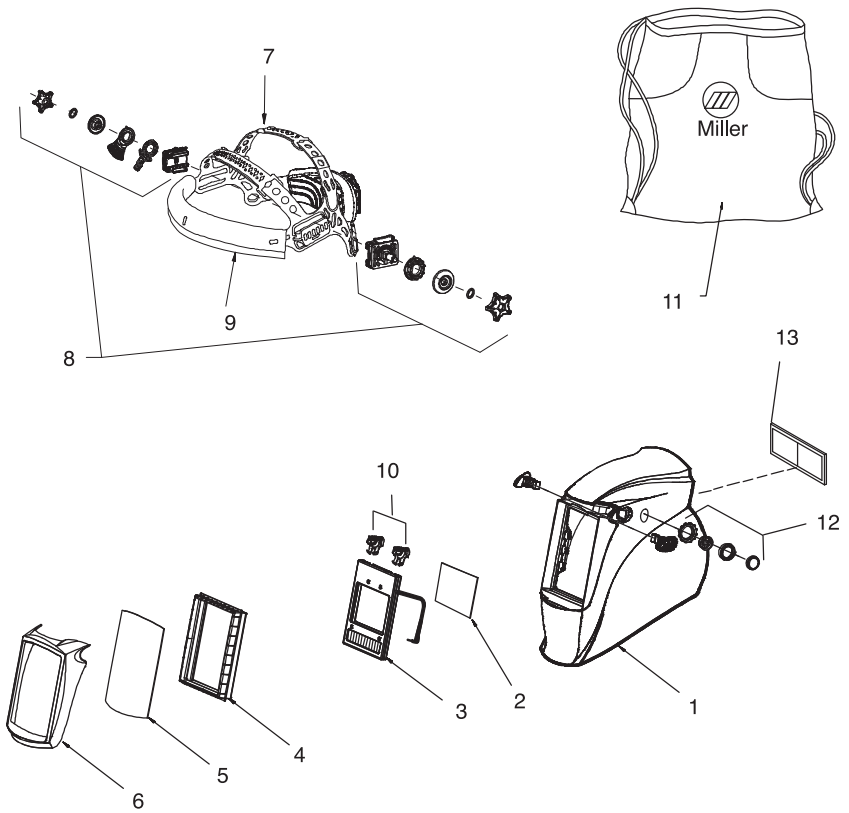

Figure 11-2. Titanium 9400 Auto-Darkening Welding Helmet

Item No.	Part No.	Description	Quantity
----------	----------	-------------	----------

Figure 11-2. Titanium 9400 Auto-Darkening Welding Helmet

1	243 530	Shell, Helmet Titanium (Includes Item 6)	1
2	216 327	Lens Cover, Inside 4-1/4 X 2-1/2 (5 Per Pkg.)	1
3	256 359	Lens Assembly, Auto-Darkening With Cable	1
4	241 977	Gasket, Lens Assembly	1
5	216 326	Lens Cover, Outside (4-11/16 X 5-5/8) (5 Per Pkg.)	1
6	243 396	Lens Holder, Front (Titanium)	1
7	256 174	Headgear Gray (Includes Items 8 And 9)	1
8	*256 178	Kit, Adjustment Angle/Stop Hardware	1
9	770 249	Headband, Fabric	1
	079 975	Replacement O-rings For Kit 256 178 (5 Per Pkg.)	1
10	216 339	Tray, Battery (Left/Right)	1
	217 043	Battery, Lithium (CR2450)	2
11	770 250	Helmet Bag – Miller	1
	♦222 003	Adapters, Hard Hat (Not Shown)	1
12	256 179	Button, Grind Mode	1
13	♦212 235	Lens, 0.75 Magnification	1
13	♦212 236	Lens, 1.00 Magnification	1
13	♦212 237	Lens, 1.25 Magnification	1
13	♦212 238	Lens, 1.50 Magnification	1
13	♦212 239	Lens, 1.75 Magnification	1
13	♦212 240	Lens, 2.00 Magnification	1
13	♦212 241	Lens, 2.25 Magnification	1
13	♦212 242	Lens, 2.50 Magnification	1

* Adjustment Hardware Kit With O-rings.

♦ Optional

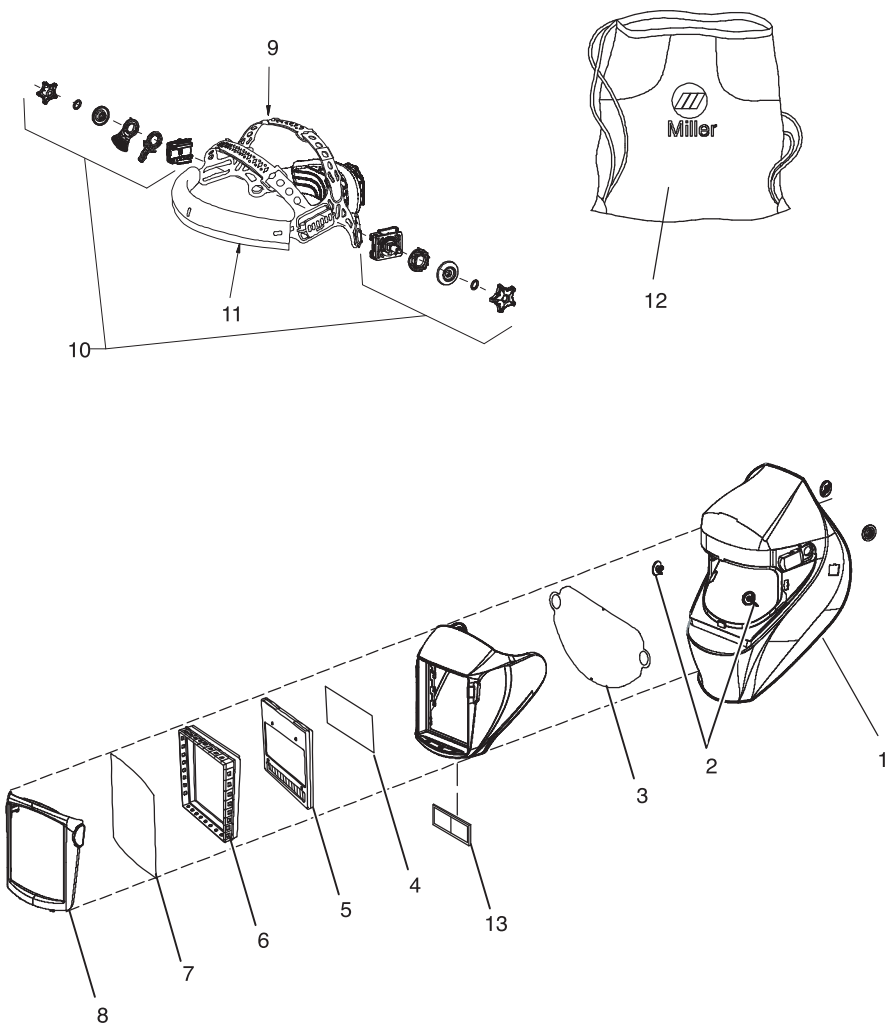

Figure 11-3. Titanium 9400i Auto-Darkening Welding Helmet

Item No.	Part No.	Description	Quantity
----------	----------	-------------	----------

Figure 11-3. Titanium 9400i Auto-Darkening Welding Helmet

1	245 820	Shell, Helmet Titanium I Series (Includes Item 6)	1
2	245 819	Clip, Retaining Grinding Shield	2
3	245 818	Lens, Grinding Shield (Clear)	1
	254 278	Lens Cover, Tear-Away	1
4	216 327	Lens Cover, Inside 4–3/16in X 2–1/2in	1
5	256 360	Lens Assembly, Auto-Dark Titanium Without Cable	1
	217 043	Battery, Lithium (CR2450)	2
6	241 977	Gasket, Lens Assembly Elite (Qr)	1
7	216 326	Lens Cover, Front 4–11/16in X 5–5/8in	1
8	245 815	Lens Holder, Front Titanium I Series	1
9	256 174	Headgear, Gray (Includes Items 10 And 11)	1
10	*256 178	Kit, Adjustment Angle/Stop Hardware Kit	1
11	770 249	Headband, Fabric	1
	079 975	Replacement O-rings For Kit 256 178 (5 Per Pkg.)	1
12	770 250	Bag, Helmet (Miller Logo)	1
	◆222 003	Adapters, Hard Hat (Not Shown)	1
13	◆212 235	Lens, 0.75 Magnification (Not Shown)	1
	◆212 236	Lens, 1.00 Magnification (Not Shown)	1
	◆212 237	Lens, 1.25 Magnification (Not Shown)	1
	◆212 238	Lens, 1.50 Magnification (Not Shown)	1
	◆212 239	Lens, 1.75 Magnification (Not Shown)	1
	◆212 240	Lens, 2.00 Magnification (Not Shown)	1
	◆212 241	Lens, 2.25 Magnification (Not Shown)	1
	◆212 242	Lens, 2.50 Magnification (Not Shown)	1

* Adjustment Hardware Kit With O-rings.

◆ Optional

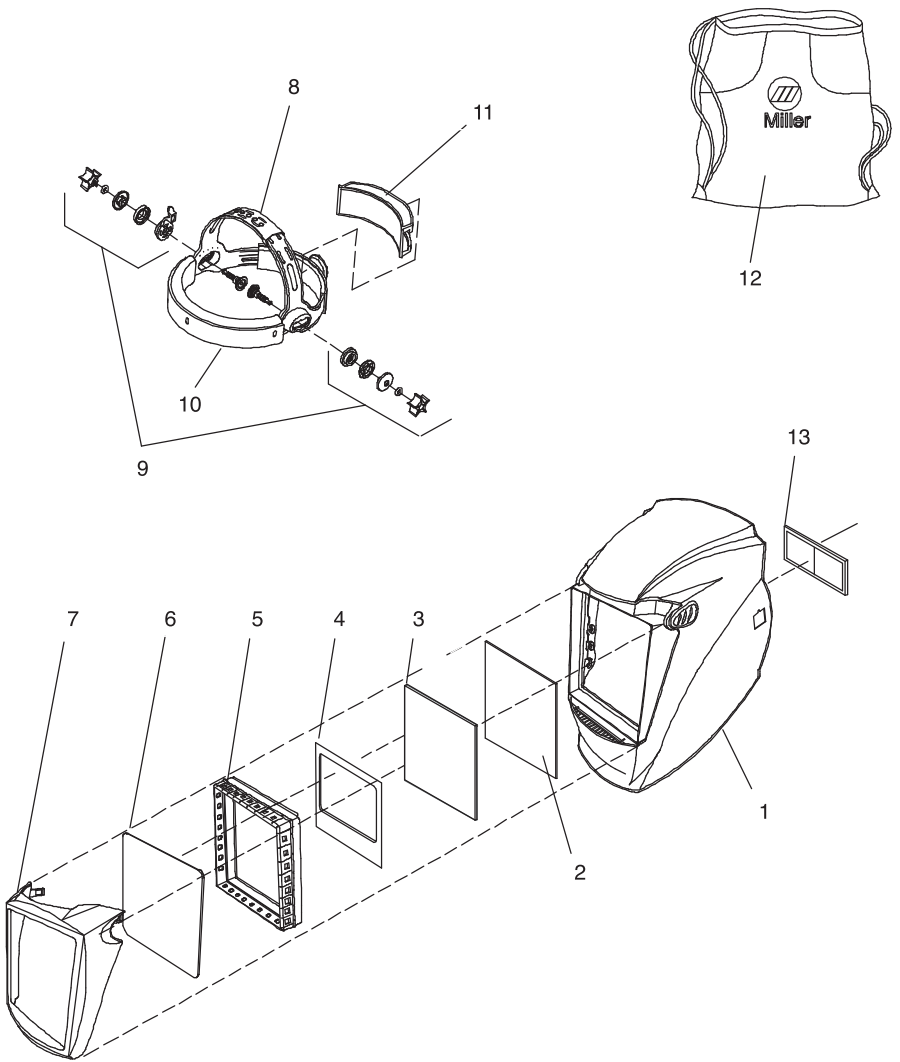

Figure 11-4. Titanium 1600 Welding Helmet

Item No.	Part No.	Description	Quantity
----------	----------	-------------	----------

Figure 11-4. Titanium 1600 Welding Helmet

1	243 530	Shell, Helmet Titanium (Elite) (Qr) (Includes Item 6)	1
2	235 628	Lens Cover, In 4-1/2 in x 5-1/4 in (Mp-10)	1
3	235 630	Filter Plate, #10 4 1/2 x 5 1/4 (Mp-10)	1
4	246 759	Aluminum Plate, Titanium 1600	1
5	245 813	Gasket, Lens Assembly Titanium 1600	1
6	216 326	Lens Cover, Front 4-11/16 in X 5-5/8 in	1
7	243 396	Lens Holder, Titanium Elite (Qr)	1
8	770 246	Headgear, Gray (Includes Items 9 And 10)	1
9	*770 248	Kit, Adjustment Angle/Stop Hardware Kit	1
10	770 249	Headband, Fabric	1
	079 975	Replacement O-rings For Kit 770 248 (5 Per Pkg.)	1
11	216 336	Cushion, Comfort (Foam Rubber)	1
12	770 250	Bag, Helmet (Miller Logo)	1
	♦222 003	Adapters, Hard Hat (Not Shown)	1
13	♦212 235	Lens, 0.75 Magnification	1
	♦212 236	Lens, 1.00 Magnification	1
	♦212 237	Lens, 1.25 Magnification	1
	♦212 238	Lens, 1.50 Magnification	1
	♦212 239	Lens, 1.75 Magnification	1
	♦212 240	Lens, 2.00 Magnification	1
	♦212 241	Lens, 2.25 Magnification	1
	♦212 242	Lens, 2.50 Magnification	1

* Adjustment Hardware Kit With O-rings.

♦ Optional

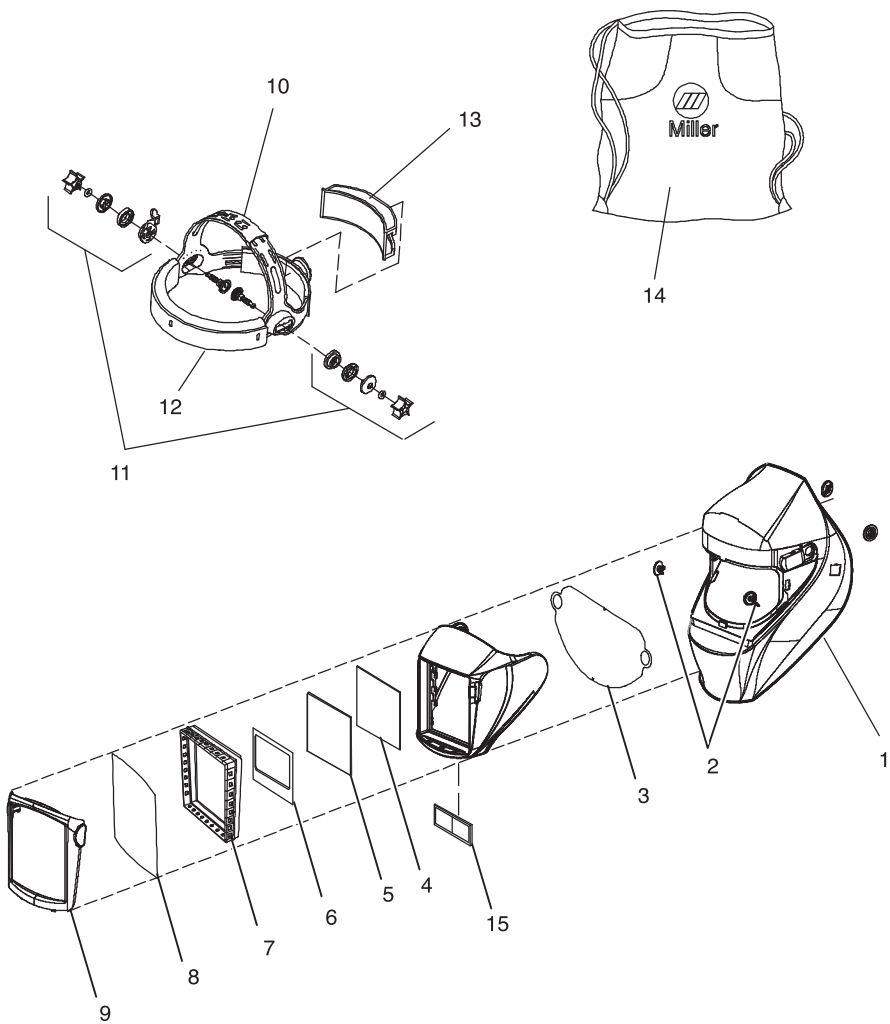

Figure 11-5. Titanium 1600i Auto-Darkening Welding Helmet

Item No.	Part No.	Description	Quantity
----------	----------	-------------	----------

Figure 11-5. Titanium 1600i Auto-Darkening Welding Helmet

1	245 820	Shell, Helmet Titanium I Series (Includes Item 6)	1
2	245 819	Clip, Retaining Grinding Shield	2
3	245 818	Lens, Grinding Shield (Clear)	1
	254 278	Lens Cover, Tear-Away	1
4	235 628	Lens Cover, Inside 4-1/2 in x 5-1/4 in (MP-10)	1
5	256 630	Filter Plate, #10 4-1/2 in x 5-1/4 in (MP-10)	1
6	246 759	Aluminum Plate, Titanium 1600	1
7	245 813	Gasket, Lens Assembly 1600	1
8	216 326	Lens Cover, Front 4-11/16 in x 5-5/8 in	1
9	245 815	Lens Holder, Front Titanium I Series	1
10	770 246	Headgear, Gray (Includes Items 10 And 11)	1
11	*770 248	Kit, Adjustment Angle/Stop Hardware Kit	1
12	770 249	Headband, Fabric	1
	079 975	Replacement O-rings For Kit 770 248 (5 Per Pkg.)	1
13	◆216 336	Cushion, Comfort (Foam Rubber)	1
14	◆770 250	Bag, Helmet (Miller Logo)	1
	◆222 003	Adapters, Hard Hat (Not Shown)	1
15	◆212 235	Lens, 0.75 Magnification (Not Shown)	1
	◆212 236	Lens, 1.00 Magnification (Not Shown)	1
	◆212 237	Lens, 1.25 Magnification (Not Shown)	1
	◆212 238	Lens, 1.50 Magnification (Not Shown)	1
	◆212 239	Lens, 1.75 Magnification (Not Shown)	1
	◆212 240	Lens, 2.00 Magnification (Not Shown)	1
	◆212 241	Lens, 2.25 Magnification (Not Shown)	1
	◆212 242	Lens, 2.50 Magnification (Not Shown)	1

* Adjustment Hardware Kit With O-rings.

◆ Optional

SECTION 12 – LIMITED WARRANTY

LIMITED WARRANTY – Subject to the terms and conditions below. Miller Electric Mfg. Co., Appleton, Wisconsin, warrants to its original retail purchaser that the new Miller equipment sold after the effective date of this limited warranty is free of defects in material and workmanship at the time it is shipped by Miller. THIS WARRANTY IS EXPRESSLY IN LIEU OF ALL OTHER WARRANTIES, EXPRESS OR IMPLIED, INCLUDING THE WARRANTIES OR MERCHANTABILITY AND FITNESS.

Miller Digital Series auto-darkening lens helmets are warranted for 3 years from the date of purchase. *Proof of purchase is required for warranty transactions so it is imperative that a copy of the original invoice or sales receipt be retained.*

For warranty transactions, contact your Miller Distributor.

Effective April 1, 2012



Visit our website at
www.MillerWelds.com



Miller Electric Mfg. Co.
An Illinois Tool Works Company
1635 West Spencer Street
Appleton, WI 54914 USA